

Campagnolo®

11TM
SPEED

CHAINS

**WARNING!**

Carefully read, follow and understand the instructions given in this manual. It is an essential part of the product, and you should keep it in a safe place for future reference.

MECHANIC QUALIFICATION - Please be advised that many bicycle service and repair tasks require specialized knowledge, tools and experience. General mechanical aptitude may not be sufficient to properly service or repair your bicycle. If you have any doubt whatsoever regarding your service/repair ability, please take your bicycle to a qualified repair shop.

INTENDED USE - This product by Campagnolo® has been designed and manufactured to be fitted and used **exclusively** on "racing" or "cyclo-cross" bicycles, with any other use explicitly excluded. Any different use of this product (like, for instance, but without any limitation, cross-country, all mountain/enduro, off-road acrobatic, downhill, four-cross, freeride, free-style, or any other type of extreme off-road cycling as defined by UCI) might cause accidents, physical injuries or even death and must therefore be considered totally inappropriate, unsuitable and not recommended.

"AN ACCIDENT" - Please note that throughout this manual, reference is made that "an accident" could occur. Any accident could result in damage to your bicycle, its components and, more importantly, could cause you or a bystander to sustain severe personal injury or even death.

LIFESPAN - WEAR - INSPECTION REQUIREMENT - The lifespan of Campagnolo® components depends on many factors, such as rider size and riding conditions. Impacts, falls, improper use or harsh use in general may compromise the structural integrity of the components and significantly reduce their lifespan. Some components are also subject to wear over time. Please have your bicycle and its components regularly inspected by a qualified mechanic for any cracks, deformation, signs of fatigue or wear (use of penetrating fluid or other visual enhancers to locate cracks on parts is recommended). Disassembly your bicycle components and especially the pedals, is required during these inspections. If the inspection reveals any deformation, cracks, impact marks or stress marks, no matter how slight, **immediately** replace the component; components that have experienced excessive wear also need **immediate** replacement. The frequency of inspection depends on many factors; check with your authorized representative of Campagnolo S.r.l. to select a schedule that is

best for you. If you weigh 82 kg/180 lbs or more, you must be especially vigilant and have your bicycle inspected more frequently (than someone weighting less than 82 kg/180 lbs) for any evidence of cracks, deformation, or other signs of fatigue or stress. Check with your mechanic to discuss whether the components you selected are suitable for your use, and to determine the frequency of inspections.

Important PERFORMANCE, SAFETY and WARRANTY Notice - The components of Campagnolo® 11s transmissions, as well as the brakes, rims, pedals and all other Campagnolo® products are designed as a single integrated system. Not to affect safety, performance, longevity, functionality and the WARRANTY, use exclusively the parts and components supplied or specified by Campagnolo S.r.l., without interfacing or replacing them with products, parts or components manufactured by other companies.

Note: Tools supplied by other manufacturers for components similar to Campagnolo® components may not be compatible with Campagnolo® components. Likewise, tools supplied by Campagnolo S.r.l. may not be compatible with components supplied by other manufacturers. Always check with your mechanic or the tool manufacturer to insure compatibility before using tools supplied by one manufacturer on components supplied by another. The user of this Campagnolo® product expressly recognizes that there are risks inherent in bicycle riding, including but not limited to the risk that a component of the bicycle can fail, resulting in an accident, personal injury or death. By his purchase and use of this Campagnolo® product, the user expressly, voluntarily and knowingly accepts and/or assumes these risks and agrees to hold Campagnolo S.r.l. harmless against any resulting damages. **If you ever have any questions, please contact your mechanic or your nearest Campagnolo® dealer for additional information.**

SAFETY RECOMMENDATIONS

- Please be advised that if the maintenance and repair procedures provided in this manual are not properly performed, or if the other instructions in this manual are not followed, an accident could occur.
- Never make any modifications whatsoever to any component of any Campagnolo® product.
- Parts which have been bent or otherwise damaged in an accident or as a result of any other impact must not be re-straightened. They must be replaced immediately with original Campagnolo® parts.
- Wear clothes which are snug-fitting and which make you visible to traffic, such as neon fluorescent or other bright colors.
- Avoid biking at night because it is more difficult for you to be seen by traffic, and it is more difficult for you to see obstructions on the ground. If you do ride at night, you should equip your bicycle with and use a headlight and a tail light.
- Never use a bicycle or bicycle component unless you are thoroughly familiar with its use and maintenance history. "Used" equipment may have been misused and abused, and can unexpectedly fail resulting in an accident.
- When riding in wet conditions, remember that the stopping power of your brakes is greatly reduced and that the adherence of the tires on the ground is considerably reduced. This makes it harder to control and stop your bicycle. Extra care is required when riding your bicycle in wet conditions to avoid an accident.
- Never spray your bicycle with water under pressure. Pressurized water, even from the nozzle of a small garden hose, can pass under seals and enter your Campagnolo components, thereby affecting its operation. Wash your bicycle and Campagnolo components by wiping them down with water and neutral soap.
- Always wear a properly fitted and fastened bicycle helmet that has been approved by ANSI or SNELL.

BEFORE EVERY RIDE

DO NOT RIDE YOUR BICYCLE IF IT DOES NOT PASS THIS PRE-RIDE TEST CORRECT ANY CONDITION BEFORE YOUR RIDE.

- Be sure that all of the components of your bicycle, including but not limited to your brakes, pedals, handgrips, handlebars, frame and seating system, are in optimum condition and suitable for use.
- Be sure that none of the components of bicycle are bent, damaged or out of alignment.
- Check to be sure that all quick release fasteners, nuts and bolts are properly adjusted. Bounce the bicycle on the ground and listen and look for anything which may be loose.
- Be sure that your wheels are perfectly centred. Spin the wheels to be sure that they do not wobble up and down or from side to side, and that they do not make contact with the fork legs or brake pads while rotating.
- Check all reflectors to make sure that they are clean, straight and securely mounted.
- Check you brake pads and cables to be sure they are in good condition.
- Test your brakes in the beginning of your ride to make sure that they are operating properly.
- Learn and follow the local bicycle laws and regulations, and obey **all** traffic signals, signs and laws while you ride.

If you ever any comments, questions or concerns, please contact your nearest Campagnolo Service Center. A list of service centers may be found on our website at www.campagnolo.com.



WARNING!

The use of sprockets or chainrings which are not marked Campagnolo® can damage the chain. This may result in its unexpected opening of the chain and cause accidents, personal injury or death.

TOOLS

**WARNING!**

All connecting and disconnecting of the Campagnolo® **11 SPEED** chains should be performed using the special Campagnolo® **UT-CN300** tool, not included in this kit (Fig.1). Use of other tools could damage the chain and/or provoke unexpected chain failure resulting in an accident, personal injury or death.

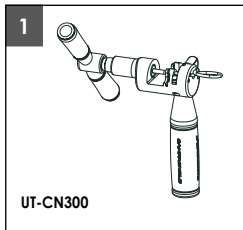
**WARNING!**

Always wear safety glasses or goggles when using Campagnolo® **UT-CN300**.

**WARNING!**

The pusher of the Campagnolo® tool **UT-CN300** is fitted with a pin with a replaceable tapered tip which is of fundamental importance for correct assembly of the bushing **ULTRA-LINK**; if the pin is worn or damaged, replace it with the special Campagnolo® **UT-CN301** spare pin. Failure to timely replace the tip pin can damage your chain, resulting in an accident, personal injury or death.

1. CHAIN INSTALLATION

**WARNING!**

An incorrectly assembled chain unexpectedly break, while riding in an accident, personal injury, or death. If you have any doubt whatsoever regarding your ability to properly perform any of the operations in this manual, please take your bicycle to a qualified repair shop.

- Determine the correct length of the chain by putting it onto the smallest sprocket and chainring and check that the dimension H (Fig. 2) does not exceed 8÷15 mm.

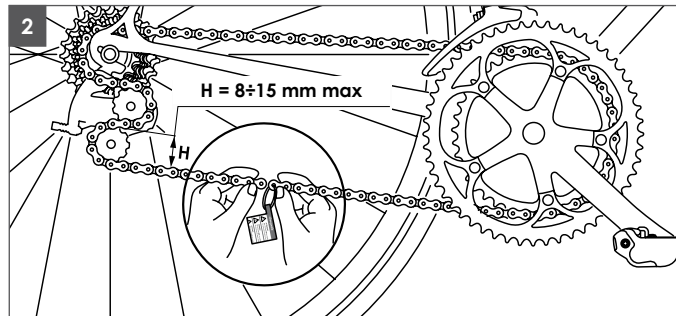

• Perform all of the following operations and remove extra links **from the side of the chain opposite the external link, which is identified by the plastic band and the adhesive "WARNING!" label (Fig. 3).**

! WARNING!

NEVER remove or modify in any way whatsoever this external link, which is permanently identified by the stamped production batch number, since it has the calibrated holes needed to close the chain.

Use of any other connecting link to join the chain may result in unexpected opening of the chain while riding, resulting in an accident, personal injury or death.

! WARNING!

To shorten chain, remove links from the opposite side of the chain.

NEVER remove or modify this link in anyway whatsoever. Carefully read, follow and understand the owner's manual before performing any operation of the chain.

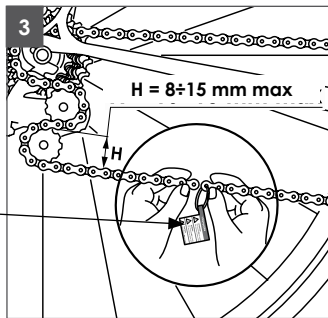

• To open the chain:

- Prepare the tool **UT-CN300** by positioning the tongue in open mode (X - Fig. 4)
- fit the link to be opened in tool **UT-CN300** (Fig. 4) taking care **to end with an internal link:**
- clamp the link with the special clamping device (Z) (Fig. 5)
- tighten the tool until the small pin emerges completely from the hole in the link (Fig. 6).

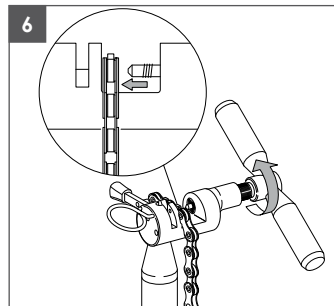
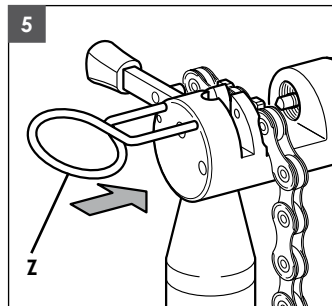
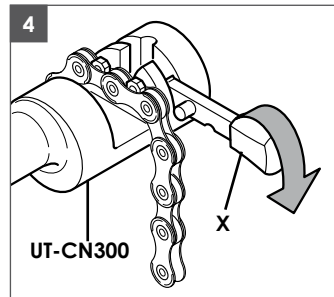

INSERTING THE BUSHING ULTRA-LINK CN-RE500

- Remove the plastic band and the adhesive "Warning" label.
- To assembly the closing pin **ULTRA-LINK CN-RE500**, place the chain on the bottom bracket shell.
- Insert the inner link (B - Fig. 7) into the outer link (C - Fig. 7), and then insert the drive part of the union bushing **ULTRA-LINK CN-RE500** (D - Fig. 7) into the hole of the link from the inside of the chain towards the outside.

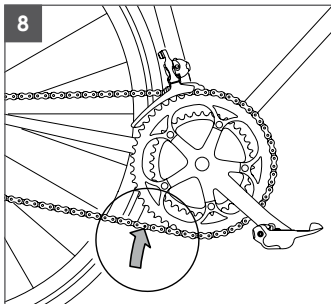
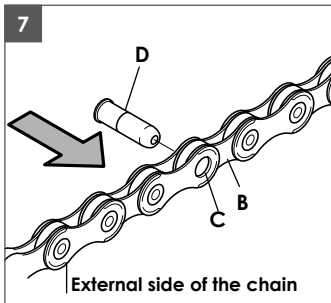

- Move the chain on to the larger chainring (keeping it on the smallest sprocket), then position the links to be closed in the area indicated in Figure 8.

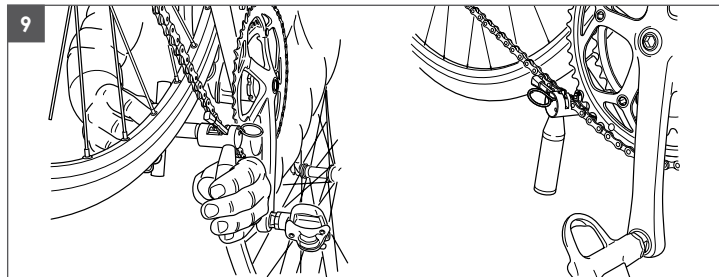

- Unscrew tool **UT-CN300**.
- Position the tool **UT-CN300** as shown in Fig. 9.
- Fit the link to be closed in the relative seats (Fig. 10).

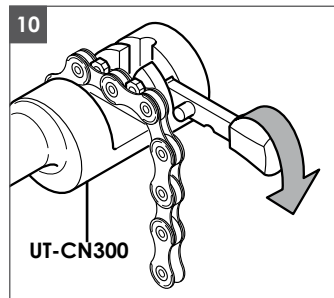

- Clamp the link with the special clamping device (Z - Fig. 11).

- Check that the tongue of tool **UT-CN300** is in the external position (Y - Fig. 11).

- Check that the tapered tip of the pusher (F) (Fig. 12) is in line with the centre of the bushing **ULTRA-LINK CN-RE500** (E) (Fig. 12).

- While exerting a uniform force, screw in the tool (Fig. 13) so that the bushing **ULTRA-LINK CN-RE500** (E) has completely entered the thickness of the chain.

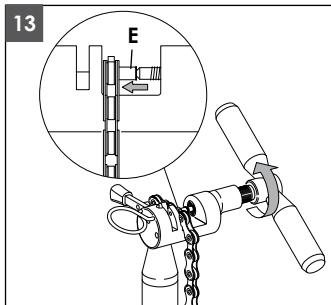
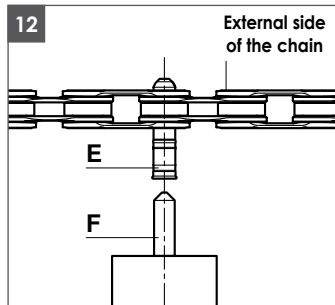
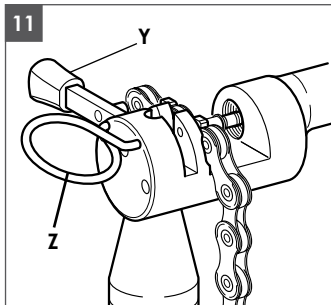

Note

In order to minimize the possibility of damaging the chain irreparably, **DO NOT TIGHTEN** the tool beyond the beat. Let the bushing **ULTRA-LINK CN-RE500** (E) protrude 0.1 mm from the inner side of the chain (Fig. 14).

- Insert the protruding part of the guide into the hole provided at the base of the tool and split it by bending (Fig. 15).

Note

The terminal part of the split guide must always remain inside the bushing.

- Remove the clamping device and remove the chain from the tool.

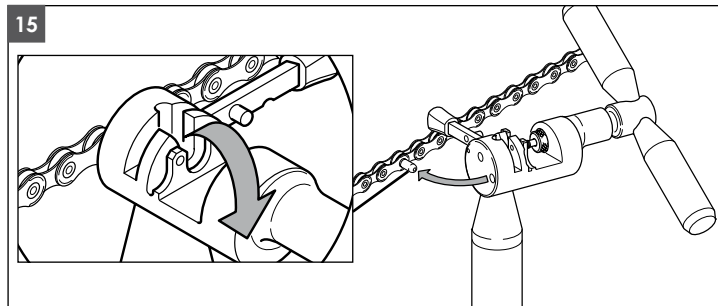
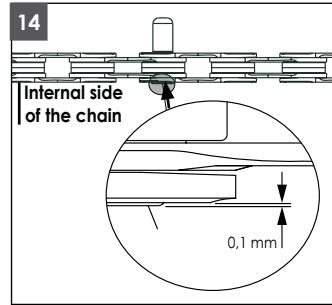

LOCKING THE BUSHING ULTRA-LINK CN-RE500

- Prepare the tool **UT-CN300** by positioning the tongue in closure mode (Y - Fig. 16).
- Position the tool **UT-CN300** as indicated in Fig. 17 (from the outside of the chain towards the inside).
- Insert the link to close into the provided seats (Fig. 18).

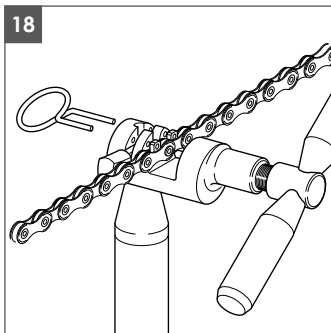
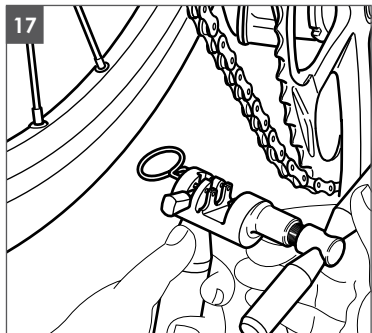
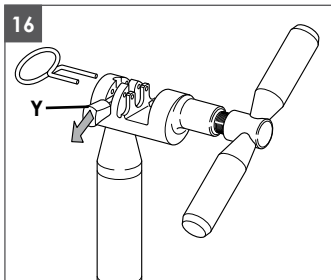

- Lock the link by means of the special locking device (Z - Fig. 19).
- Check that the tapered tip of the pusher is in line with the centre of the bushing **ULTRA-LINK CN-RE500** (Fig. 20).
- Screw in the tool to bring the pusher into contact with the protruding end of the **Ultra-link CN-RE500** bush, turning it by about 3/4 of a turn and exerting moderate force till distorted (Fig. 21).

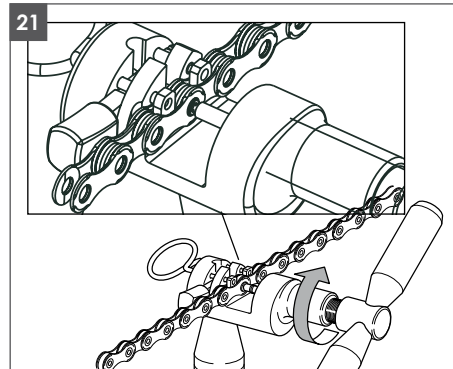
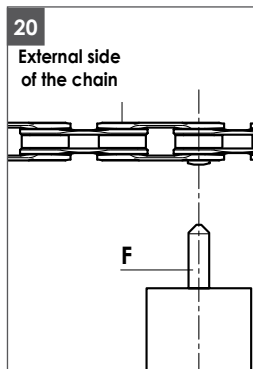
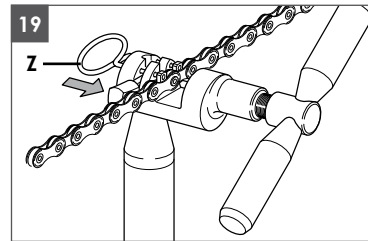

- The slight protrusion (X) (towards the external side of the chain) of the small pin (E) from the link (Fig. 22) is entirely normal and does not obstruct normal chain movement.

NEVER try to eliminate this protrusion!

- Make sure that chain closure does not present any "harsh points" or links that do not bend freely (Fig. 23).

Free the joints as required with delicate lateral bending of the links (Fig. 24).

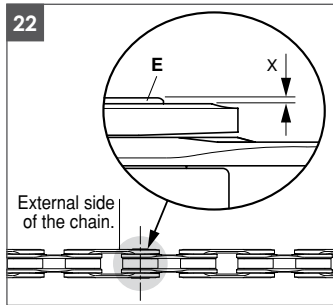

23

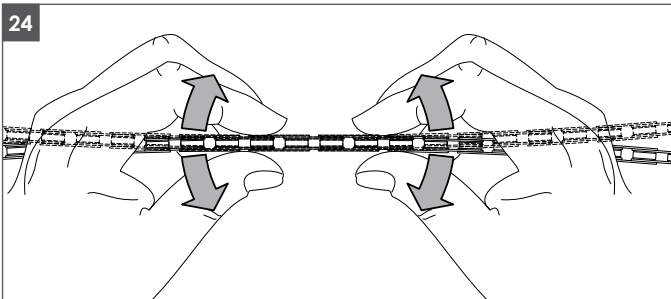
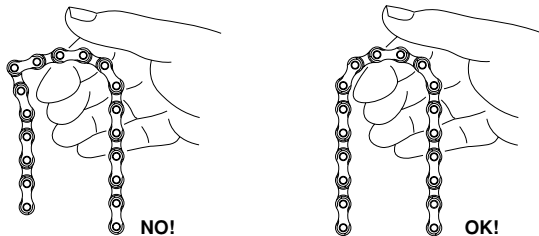

2. CHAIN OPENING

ATTENTION!

If it becomes necessary to open and close the chain (which can be done only twice), use only the special Campagnolo Ultra-link CN-RE500 pin with Campagnolo UT-CN300 tool.

The use of pin produced by different manufacturers can damage the chain. A damaged chain can break, even suddenly, and cause accidents, injuries and even death.



WARNING!

Opening and closing the chain on more than two occasions can result in the chain unexpectedly failing while riding, resulting in an accident, personal injury or death.

- Get the special Campagnolo® bushing **ULTRA-LINK CN-RE500**
- Only and exclusively use the tool **UT-CN300**.

Identify the opening link on the chain; this must be different and away from the one used for closing the first time (a link that can be recognizable from the impression showing the production batch).

Note

To open the chain, carry out the operations indicated in chapter 1 "Chain installation", using the Campagnolo® tool **UT-CN300** only.

3. CHAIN MAINTENANCE

- The life of the chain depends on conditions of use and on the frequency and quality of maintenance. To keep the chain in good condition, cleaning and lubrication must therefore be repeated frequently, especially if it is subjected to heavy-duty use (i.e. after washing your bicycle, after every ride in wet, dusty or muddy conditions etc.).
- Do not remove the chain for cleaning and lubrication.
- Before lubricating, thoroughly clean the drive system (chain, sprocket set, chainrings and derailleur pulleys) with a brush or cloth saturated with an appropriate degreaser or detergent.
- Lubricate the chain.
- After applying the lubricant move the cranks and engage all possible gear combinations in order to thoroughly lubricate the entire drive system.
- Thoroughly clean any residual lubricant from the bicycle and floor.
- At the end of the lubrication operation, **CAREFULLY** degrease rims and brake pads with acetone.



WARNING!

- Traces of lubricant on the rims and brake pads can reduce or eliminate the braking capabilities of your bicycle, resulting in an accident, personal injury or death.
- Using poor-quality or incorrect lubricant may damage the chain and cause excessive wear or damage to the system. A damaged drive system can malfunction, resulting in an accident, personal injury or death.

NOTE

Never spray your bicycle with water under pressure. Pressurized water, even from the nozzle of a small garden hose, can pass seals and enter into your Campagnolo® components, damaging them beyond repair. Wash your bicycle and Campagnolo® components by wiping them down with water and neutral soap.

**WARNING!**

Salt water environments (as found on winter roads and near the seaside) can cause galvanic corrosion on most bike parts. Carefully rinse, clean, dry and re-lubricate all exposed parts to avoid damage, malfunctions and accidents.

Campagnolo S.r.l. reserves to modify the content of this manual without notice. The updated version will always be available www.campagnolo.com. On our website you will also find information on the other Campagnolo® products and the spare parts catalogue.

4. CHAIN REPLACEMENT

A chain typically lasts between 2,000 miles and 5,000 miles, depending on the conditions of use and on the frequency and quality of maintenance operations. Use a high precision caliper gauge to measure, in different points of the chain, the length as indicated in fig. 25. If even one of the measurement is longer than 132.60 mm **the chain must immediately be replaced.**

**WARNING!**

Failure to timely replace the chain can result in unexpect chain failure while riding, resulting in an accident, personal injury or death.

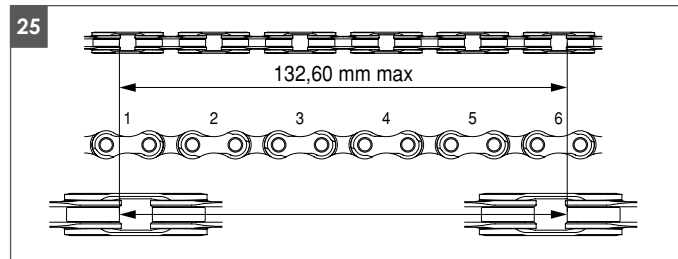

25

132,60 mm max