



WARNING!

Carefully read, follow and understand the instructions given in this manual. It is an essential part of the product, and you should keep it in a safe place for future reference.

MECHANIC QUALIFICATION - Please be advised that many bicycle service and repair tasks require specialized knowledge, tools and experience. General mechanical aptitude may not be sufficient to properly service or repair your bicycle. If you have any doubt whatsoever regarding your service/repair ability, please take your bicycle to a qualified repair shop.

INTENDED USE - These Campagnolo® wheels are designed and manufactured for use only on road racing style bicycles that are ridden only on smooth road or track surfaces. Any other use of these wheels, such as off-road or on trails is **forbidden**.

"AN ACCIDENT" - Please note that throughout this manual, reference is made that "an accident" could occur. Any accident could result in damage to your bicycle, its components and, more importantly, could cause you or a bystander to sustain severe personal injury or even death.

LIFESPAN - WEAR - INSPECTION REQUIREMENT - The lifespan of Campagnolo® wheels depends on many factors, such as rider size and riding conditions. Impacts, falls, improper use or harsh use in general may compromise the structural integrity of the components and significantly reduce their lifespan. Some components are also subject to wear over time. Please have your bicycle and its components regularly inspected by a qualified mechanic for any cracks, deformation, signs of fatigue or wear (use of penetrating fluid or other visual enhancers to locate cracks on parts is recommended). Disassembly your bicycle components and especially the pedals, is required during these inspections. If the inspection reveals any deformation, cracks, impact marks or stress marks, no matter how slight, immediately replace the component; components that have experienced excessive wear also need immediate replacement. The frequency of inspection depends on many factors; check with your authorized representative of Campagnolo S.r.l. to select a schedule that is best for you.

- If you weigh over 109 kg/240 lbs we advise you not to use this product. Non compliance with this warning can damage the product irreversibly.
- If you weigh 82 kg/180 lbs or more, you must be especially vigilant and have your bicycle inspected more frequently (than someone weighing less than 82 kg/180 lbs). Check with your mechanic to discuss whether the wheels you selected are suitable for your use, and to determine the frequency of inspections.

Important PERFORMANCE, SAFETY and WARRANTY Notice - The parts and components of Campagnolo® 9s, 10s, 11s drivetrains, braking systems, rims, pedals and all other Campagnolo® products, are designed as a single integrated system. To avoid compromises in terms of safety, performance, durability, function, and to prevent voiding the WARRANTY, use only the parts and components supplied or specified by Campagnolo S.r.l., without interfacing them with or substituting them with products, parts or components manufactured by other companies.

Note: Tools supplied by other manufacturers for components similar to Campagnolo® components may not be compatible with Campagnolo® components. Likewise, tools supplied by Campagnolo S.r.l. may not be compatible with components supplied by other manufacturers. Always check with your mechanic or the tool manufacturer to insure compatibility before using tools supplied by one manufacturer on components supplied by another.

The user of this Campagnolo® product expressly recognizes that there are risks inherent in bicycle riding, including but not limited to the risk that a component of the bicycle can fail, resulting in an accident, personal injury or death. By his purchase and use of this Campagnolo® product, the user expressly, voluntarily and knowingly accepts and/or assumes these risks and agrees to hold Campagnolo S.r.l. harmless against any resulting damages.

If you ever have any questions, please contact your mechanic or your nearest Campagnolo® dealer for additional information.

1. THE PACKAGE

The package your have purchased contains the following items (Fig. 1):

- A - The wheel;
 - B - The wheel carry-bag (if envisaged);
 - C - "Owner's Manual PART 1" and "Owner's Manual PART 2 - NEUTRON™ ULTRA™";
 - D - The quick release;
 - E - The standard lock ring for clamping the sprocket set (rear wheels only);
- ⚠ Caution!**
The standard lock ring is not compatible with sprocket sets starting from 11.
- F - The rim tape.

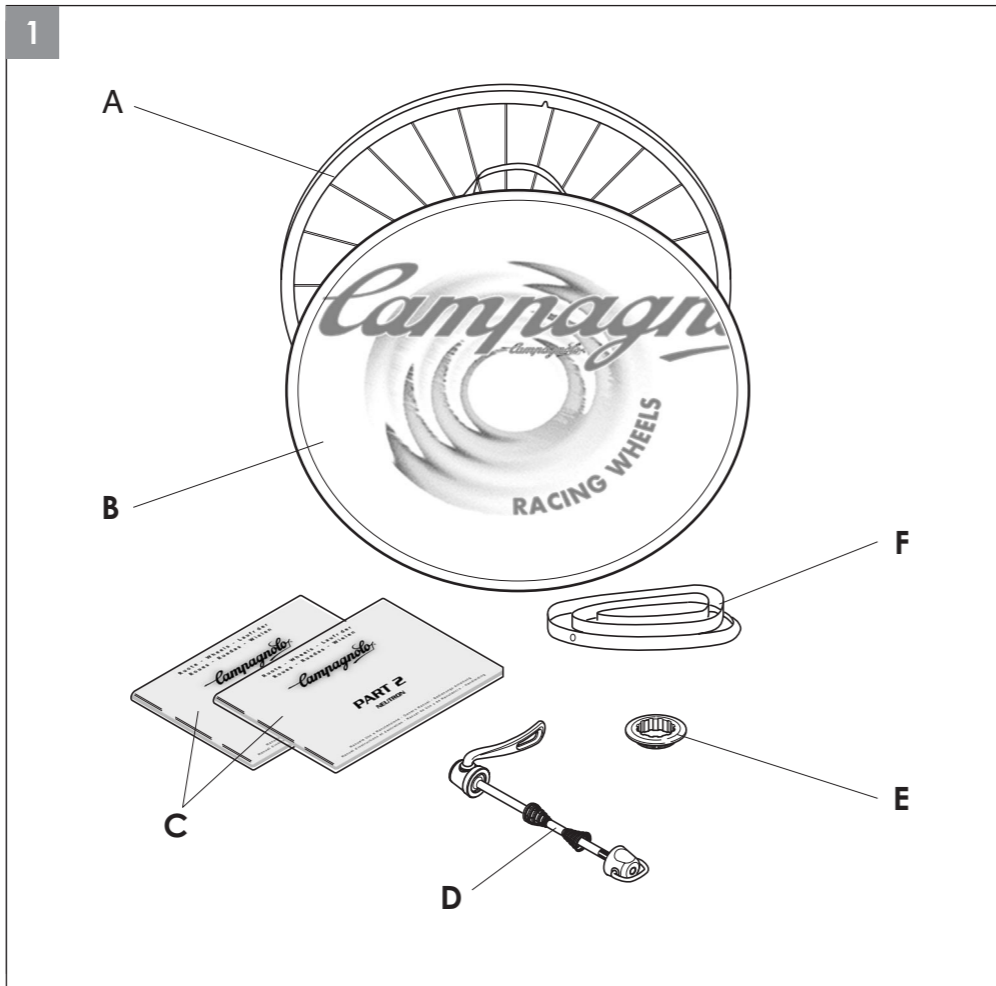

2. TECHNICAL SPECIFICATIONS

| | |
|---|---|
| Rim diameter: 622x15C | Quick release types: front QF6-20 - rear QR6-20 |
| Hub type: ALUMINIUM / CARBON | |
| O.L.D.: front: 100 mm - rear: 130 mm | Inflation pressure: see table "Maximum operating pressures" |
| Use: road racing on smooth road or track surfaces only . | |

| MAXIMUM OPERATING PRESSURES | TYRE WIDTH | | | |
|-----------------------------|------------|------------------|-------------------|------------------|
| | mm | 20 | 23 | 25 |
| | Inch | 0.80 | 0.90 | 1.00 |
| RIM DIMENSIONS | 13C | 8 BAR 116 PSI | 8 BAR 116 PSI | 8 BAR 116 PSI |
| | 15C | | 10 BAR 145 PSI | 9 BAR 131 PSI |

SPOKES TECHNICAL SPECIFICATIONS



WARNING!

Only use genuine Campagnolo® spokes for your specific type and model of wheel. Failure to use correct spokes can result in an accident, personal injury or death.

Front wheel:

- Spokes type: AERO 2/1.5/2 - black
- Spokes number: 22
- Spokes length: 293,7 mm
- Recommended tension: 60÷80 Kg

Rear wheel - freewheel side:

- Spokes type: AERO 2/1.2/2 - black
- Spokes number: 12
- Spokes length: 292 mm
- Recommended tension: 130÷150 Kg

Rear wheel - side opposite the freewheel:

- Spokes type: AERO 2/1.5/2 - black
- Spokes number: 12
- Spokes length: 293,75 mm
- Recommended tension: 60÷80 Kg

3. TIRES

! WARNING! Rim-Tire Compatibility

Campagnolo rims are very precise dimensionally. If a tire is too easy to install on a Campagnolo rim, that tire is most likely too big and will not seat properly on the rim. If a tire is too difficult to install, that tire is most likely too small. Use only high quality tires that require the use of tire levers and a reasonable installation effort. Using talcum powder on the tire will make installation easier. Using a tire that does not fit properly on the rim can cause unexpected tire failure, resulting in an accident, personal injury or death.

- The wheel you have purchased is designed to use clincher tires.
- Before fitting the tires, cover the rim using **only** the tape (part no. **WH-RT01**) supplied with the rim.
- Before fitting the tires, check that the diameter indicated on the tire is 622 and that the cross-section is between 23 and 25 mm, to insure that the tire and wheel are compatible.

! WARNING!

Failure to properly install the tire can cause sudden and unexpected loss of tire pressure, resulting in an accident, personal injury or death.

INSTALLING CLINCHER TIRES

Be sure that you do not damage or otherwise bend any portion of the rim when installing the tire.

- Insert one side of the clincher into the seat provided on the rim (Fig. 2).
- Slightly inflate the inner tube to facilitate assembly.
- Insert the valve through the hole in the rim, and then position the remainder of the inner tube between the rim and the clincher tire.
- Insert the second side of the clincher tire into its seat in the rim.

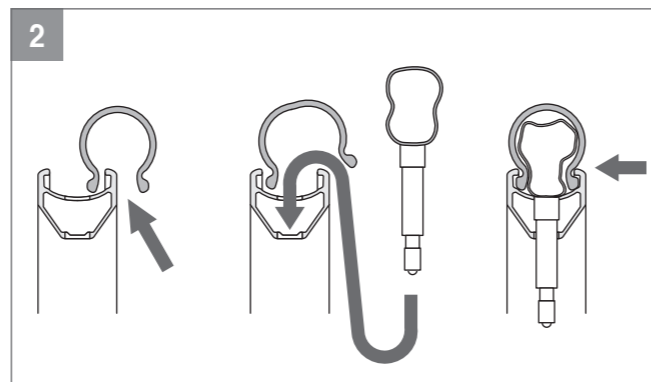

- In order to properly set the tube and tire on the rim, you should first inflate the tube to between 2 and 3 atmospheres. You should then manually set the tube and tire on the rim, making sure that the tube is positioned correctly within the tire and that the tire is positioned correctly on the rim. You may then fully inflate the tube to the correct working pressure. Please inflate the tube slowly, making sure that you maintain the correct positioning of the tube and tire on the rim.

INFLATING AND DEFLATING THE TIRE

- **To inflate the tire:** remove the cap, unscrew the valve and inflate using a compressor or a pump with a pressure gauge to obtain the required pressure, then tighten the valve and re-fit the cap.
- **To deflate the tire:** remove the cap, slightly unscrew the valve, then press it until the required pressure is obtained; tighten the valve and re-fit the cap.

! WARNING!

- **Never exceed the maximum pressure recommended by the tyre manufacturer.**
 - **The inflating pressure of the tyres must NOT exceed the LOWER pressure level between the maximum pressure stated by the tyre manufacturer and the value recommended by the rim manufacturer.**
- Excessive tire pressure reduces the grip of the tire on the road and increases the risk that the tire will unexpectedly burst. Inflation pressure that is too low reduces tire performance and increases the probability of sudden and unexpected loss of tire pressure. In addition, premature wear and damage to the rim may occur.**

! WARNING!

Incorrect tire pressure could cause tire failure or loss of control of the bicycle, resulting in an accident, personal injury or death.

4. REPLACING THE RIM

- Before commencing wheel disassembly operations, write on a piece of paper the original layout of the rim and the spoke arrangement to ensure that the wheel can be re-assembled correctly.
- Only use new, original Campagnolo® spare parts.
- Always prevent the rotation of the spokes when nuts are tightened or loosened. Make sure that no damage is caused to the surface of the spokes.
- The water discharge hole must be on the side opposite the freewheel.

CAUTION!

Take special care when handling the spokes during assembly to prevent accidentally scratching the rim.

- Using a 5 mm hex wrench, unscrew the nuts on all wheel spokes by one turn (Fig. 4), holding them steady to prevent rotation.

WARNING!

Using wheels that have not been centred properly or which have broken or damaged spokes may result in accidents, personal injury or death.

- For each spoke, completely unscrew the nut, remove the pad and slide the spoke out of the rim.
- Fit the LH wheel spokes first and then the RH wheel spokes.
- The holes for the RH and LH spokes are not aligned but slightly offset respectively to right and left.

NEVER FIT A LH SPOKE IN A RH HOLE AND VICE VERSA.

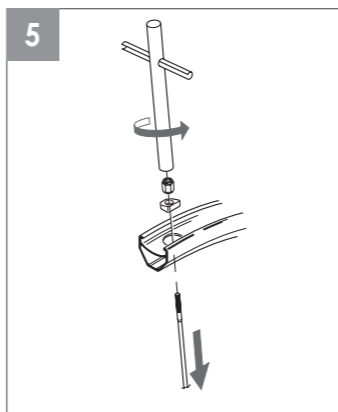
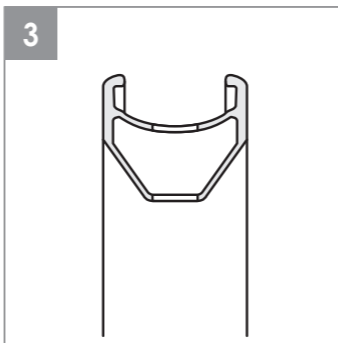
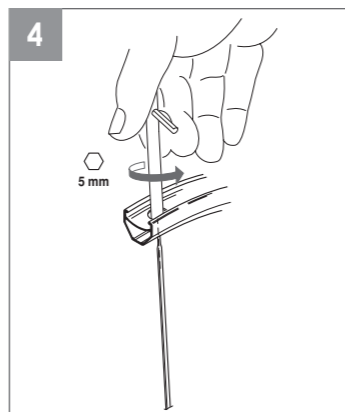

- For every spoke (Fig. 6):
 - insert the new spoke in the hole in the new rim;
 - fit the plate on the spoke, keeping the concave part facing outwards and position it in the special groove on the rim; when fitting a spoke on the LH side of the wheel, the long side of the plate must face leftwards and vice versa, as illustrated in figure 5.
 - check that plates and barrels on the hub remain in position, then tighten the nut.

Attention

After completing the operation, check that the flat spoke (aero) is oriented in an aerodynamic position (Fig. 7).

WARNING!

When fitting the wheel, check that the plates remain in position since an incorrectly positioned plate may cause irreparable damage to the profile of the rim when tensioning the spokes. This damage could cause the rim to unexpectedly fail, resulting in an accident, personal injury or death.

- Perform these operations for all spokes.
- Following the operations described in Section 5 of the "Owner's Manual - PART 1":
 - Tighten and Settle the Spokes;
 - Check centering and wheel dishing.

WARNING!

Rim wears out with use. Check wear status, especially on the braking track on the side of the rim, regularly and replace when worn. A worn out rim may suddenly and unexpectedly fail resulting in an accident, personal injuries or death.

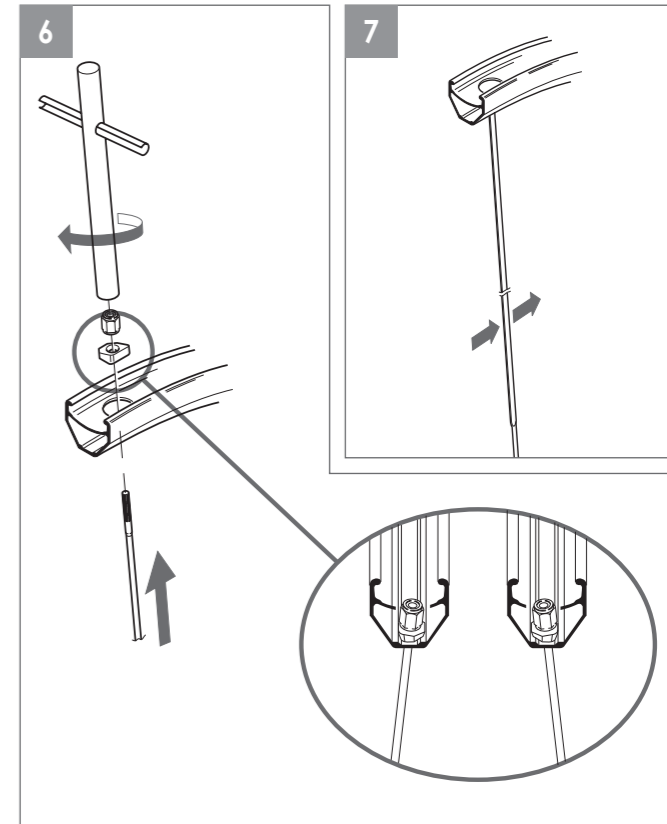

5. REPLACING A SPOKE



CAUTION!

Always wear protective gloves and glasses while working on the spokes.

5.1 - FRONT WHEEL AND REAR WHEEL ON THE SIDE OPPOSITE THE FREEWHEEL

- Before proceeding with assembly, check in the technical specifications on page 3 the type and length of the spoke to be replaced, the recommended value and the maximum value which must not be exceeded when tightening the spokes.
- Check that there are no residues of sand or any other foreign material inside the rim and, if necessary, remove them with a jet of compressed air.
- Obtain an original Campagnolo® replacement spoke.
- Always prevent the rotation of the spokes when nuts are tightened or loosened. Make sure that no damage is caused to the surface of the spokes.



CAUTION!

Take special care when handling the spokes during assembly to prevent accidentally scratching the rim.

- Using a 5 mm hex wrench, completely unscrew the nut of the spoke to be replaced (Fig. 8), holding the latter steady to prevent rotation.
- Remove the nut and the plate, then slide the spoke out of the rim (Fig. 9).
- Using a stiff blade (such as small knife) positioned as indicated in fig. 10 and taking care not to damage the hub or the spokes, remove the side covers (A) from the hub.

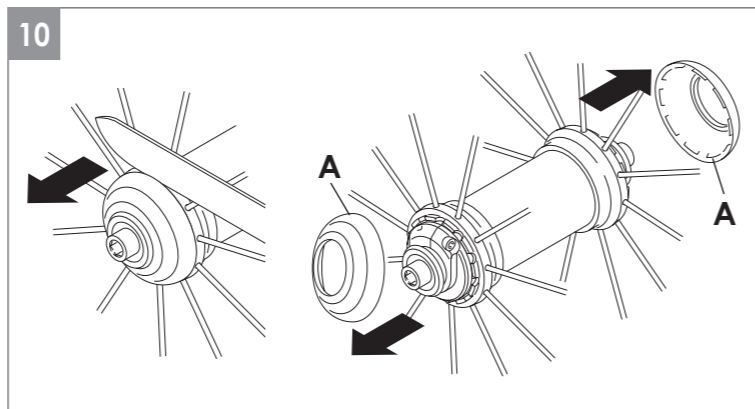
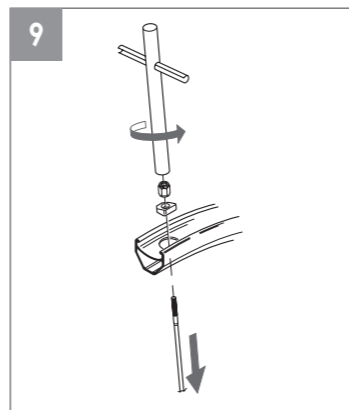
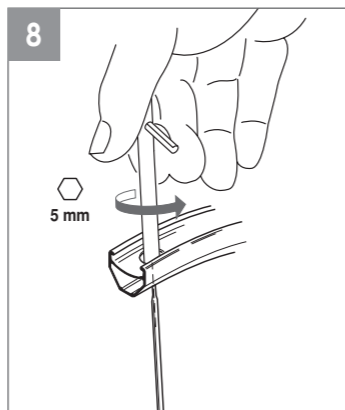

- Unscrew the locking nut (B - Fig. 11) with a fully inserted 5 mm Allen wrench; counter the rotation of the axle with another 5 mm Allen wrench fully inserted on the opposite end of the axle itself.
- Using a 2.5 mm Allen wrench, slacken the screw by 3 turns (C - Fig. 12).
- Unscrew and remove the lock ring (D - Fig. 13), remove the ring (E - Fig. 13), then slide out the axle (F - Fig. 13).
- Slide out the spoke to be replaced (G - Fig. 14) from the hub.

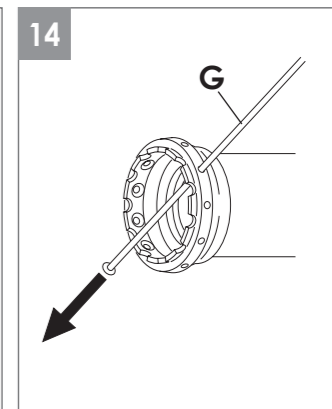
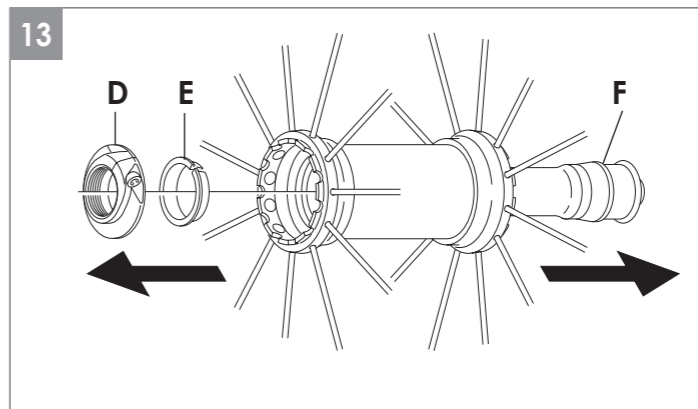
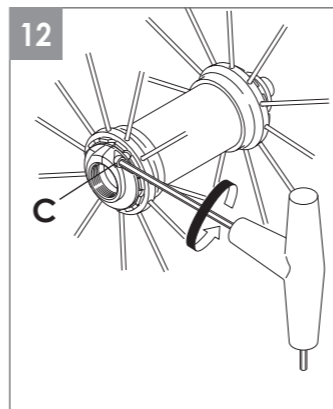
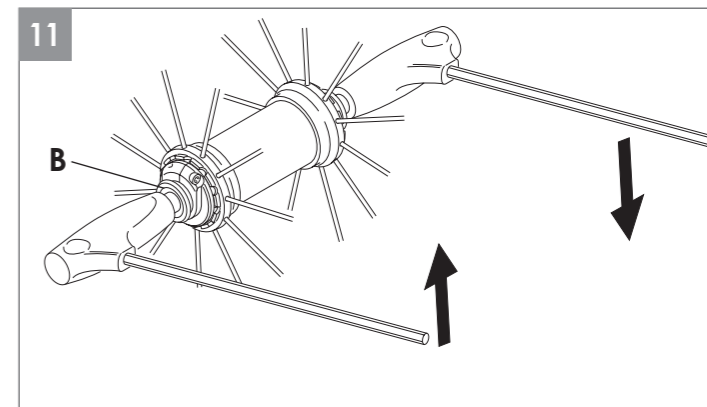

- Insert the new spoke (H - Fig. 15) in the hole in the hub.
- Fit the plate on the spoke, keeping the concave part facing outwards and position it in the special groove on the rim; when fitting a spoke on the LH side of the wheel, the long side of the plate must face leftwards and vice versa, as illustrated in figure 16.
- Tighten the nut.

**WARNING!**

When fitting the wheel, check that the plates remain in position since an incorrectly positioned plate may cause irreparable damage to the profile of the rim when tensioning the spokes. This damage could cause the rim to unexpectedly fail, resulting in an accident, personal injury or death.

- Refit the hub, performing disassembly operations in reverse order.

Attention

When inserting the axle, be careful not to move the ball bearings out of their seats.

Attention

After completing the operation, check that the flat spoke (aero) is oriented in an aerodynamic position (Fig. 7 - Page 7).

- Following the operations described in Section 5 of the "Owner's Manual - PART 1":
 - Tighten and Settle the Spokes;
 - Check centering and wheel dishing.
- After having replaced the spoke and tensioned and centered the wheel, adjust the hub (see section 7).

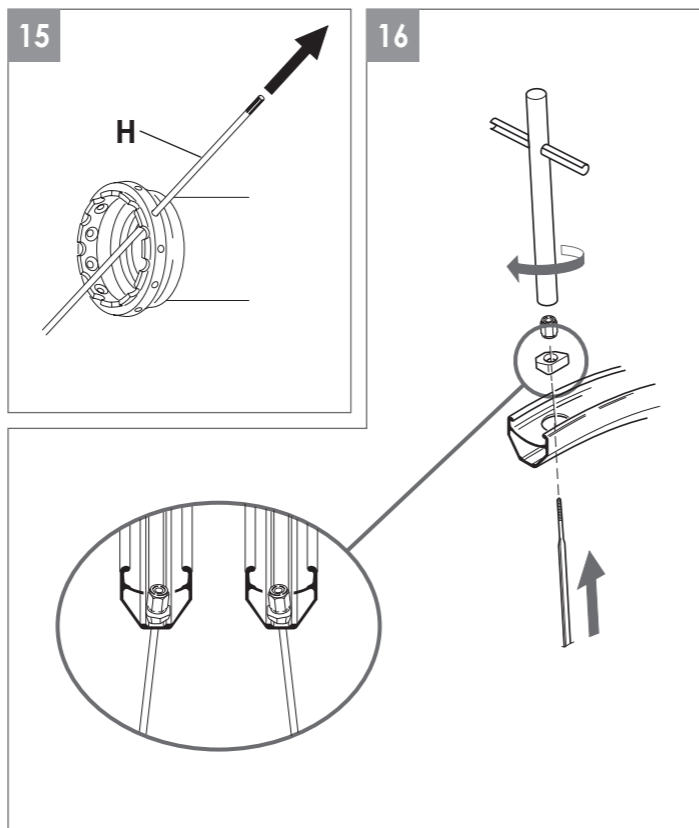
**5.2 - REAR WHEEL ON THE FREEWHEEL SIDE**

- Before proceeding with assembly, check in the technical specifications on page 3 the type and length of the spoke to be replaced, the recommended value and the maximum value which must not be exceeded when tightening the spokes.
- Check that there are no residues of sand or any other foreign material inside the rim and, if necessary, remove them with a jet of compressed air.
- Obtain an original Campagnolo® replacement spoke.
- Always prevent the rotation of the spokes when nuts are tightened or loosened. Make sure that no damage is caused to the surface of the spokes.

**CAUTION!**

Take special care when handling the spokes during assembly to prevent accidentally scratching the rim.

- Remove the sprocket set (Section 2 of the "Owner's Manual - PART 1).
- Using a 5 mm hex wrench, completely unscrew the nut of the spoke to be replaced, holding the latter steady to prevent rotation, remove it, remove the plate and then slide the spoke out of the rim (Fig. 17).

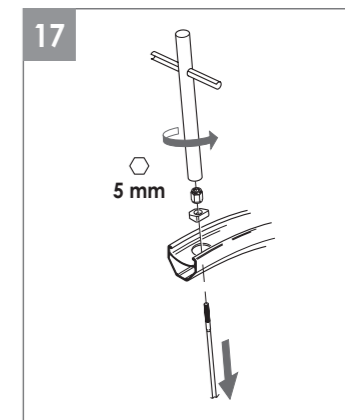

- Remove the spoke (A - Fig. 18).

! WARNING!

If necessary, first lift the spoke overlapping the one to be replaced and, after assembly of the new spoke, make sure it is returned to exactly the same position.

- Insert the new spoke in the hole in the rim.
- Fit the plate on the spoke, keeping the concave part facing outwards and position it in the special groove on the rim; when fitting a spoke on the LH side of the wheel, the long side of the plate must face leftwards and vice versa, as illustrated in figure 19.
- Tighten the nut (Fig. 19).

! WARNING!

When fitting the wheel, check that the plates remain in position since an incorrectly positioned plate may cause irreparable damage to the profile of the rim when tensioning the spokes. This damage could cause the rim to unexpectedly fail, resulting in an accident, personal injury or death.

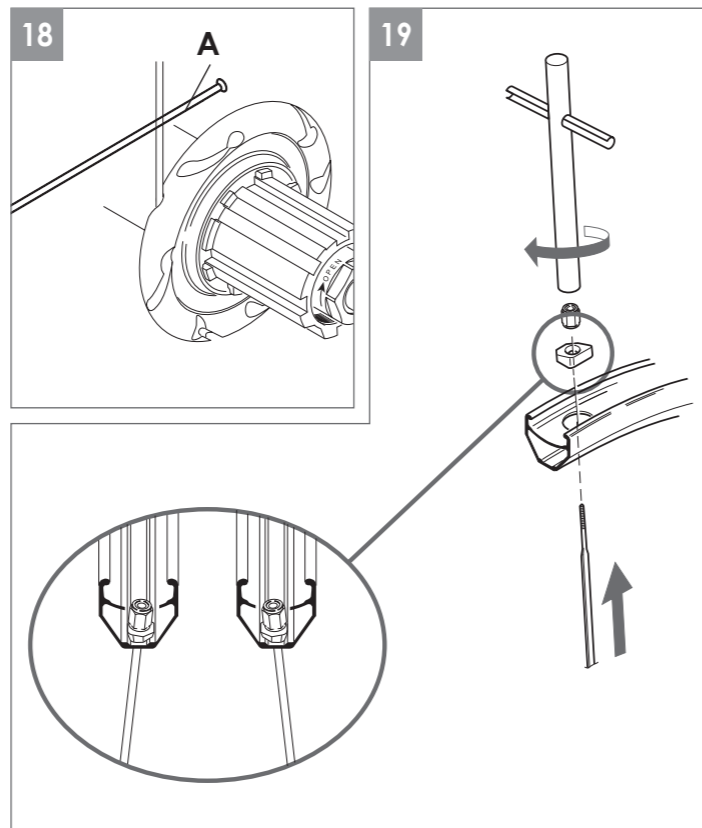

- Insert the new spoke in the specific seat in the hub.
- If necessary, reposition the overlapping spoke, making sure that the overlap is correct where the two meet.

Attention

After completing the operation, check that the flat spoke (aero) is oriented in an aerodynamic position (Fig. 20).

- Following the operations described in Section 5 of the "Owner's Manual - PART 1":
 - Tighten and Settle the Spokes;
 - Check centering and wheel dishing.
- After having replaced the spoke and tensioned and centered the wheel, adjust the hub (see section 7).

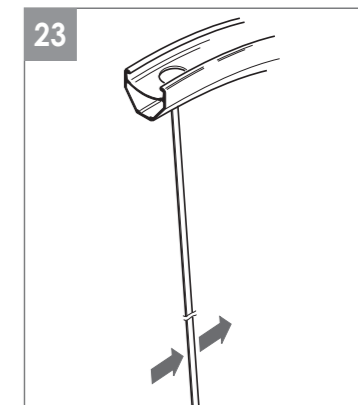

6. DISASSEMBLY, ASSEMBLY AND LUBRICATION OF HUBS



CAUTION!

Always wear protective gloves and glasses while working on the hubs.

NEUTRON™ ULTRA™ wheel hubs do not have lubrication holes, so they have to be removed to perform this operation.

6.1 - DISASSEMBLY AND ASSEMBLY OF THE FRONT HUB

- Using a stiff blade (such as small knife) positioned as indicated in fig. 21 and taking care not to damage the hub or the spokes, remove the side covers (A) from the hub.
- Unscrew the locking nut (B - Fig. 22) with a fully inserted 5 mm Allen wrench; counter the rotation of the axle with another 5 mm Allen wrench fully inserted on the opposite end of the axle itself.
- Using a 2.5 mm Allen wrench, slacken the screw by 3 turns (D - Fig. 23).

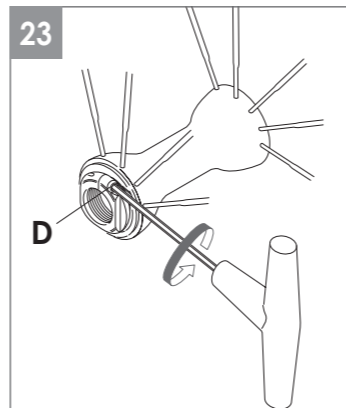
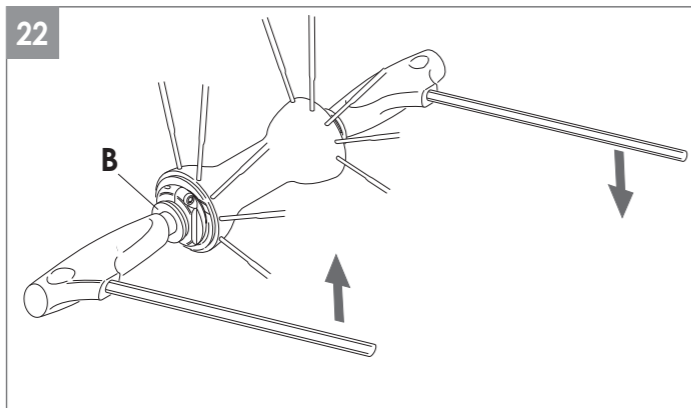
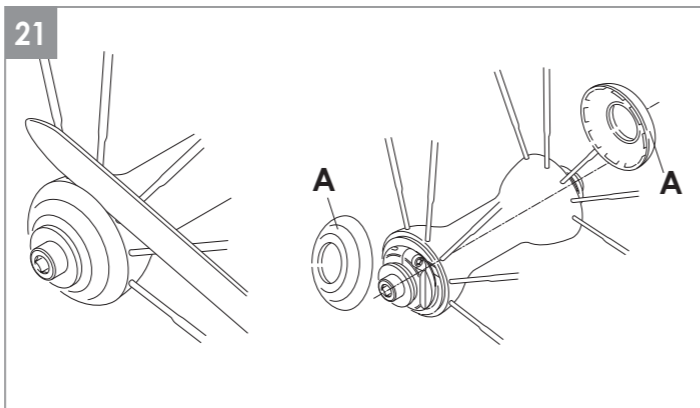

- Unscrew and remove the lock ring (C - Fig. 24), press the axle (G - Fig. 24) towards the hub body, remove the ring (F - Fig. 24), the cone (H - Fig. 24), slide out the axle (G - Fig. 24) from the hub, remove the cone (I - Fig. 24), the gaskets (J - Fig. 24) taking care not to damage it and the ball bearings (K - Fig. 24).

- If it is necessary to replace the cups, contact a Campagnolo® Service Center.

- Proceed to refit the system performing disassembly operations in reverse order.

Attention

When inserting the axle, be careful not to move the ball bearings out of their seats.

- Tighten the locking nut (B - Fig. 25) to a torque setting of 12 N.m - 8.8 lb.ft.

- Adjust the hub as illustrated in section 7.

24

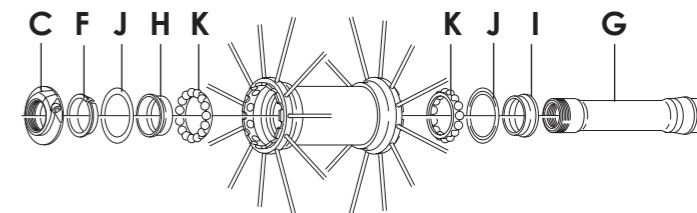

25

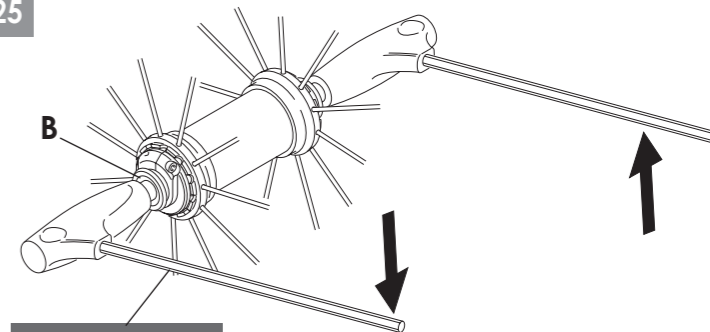

6.2 - DISASSEMBLY AND ASSEMBLY OF THE REAR HUB

- Remove the sprocket set (Section 2 of the "Owner's Manual - PART 1).
- Using a stiff blade (such as small knife) positioned as indicated in fig. 26 and taking care not to damage the hub or the spokes, remove the side covers from the hub (**A** - Fig. 26) from the hub.
- Unscrew the locking nut (**B** - Fig. 27) with a fully inserted 5 mm Allen wrench; counter the rotation of the axle with another 5 mm Allen wrench fully inserted on the opposite end of the axle itself.
- Using a 2.5 mm Allen wrench, slacken the screw by 3 turns (**D** - Fig.28).

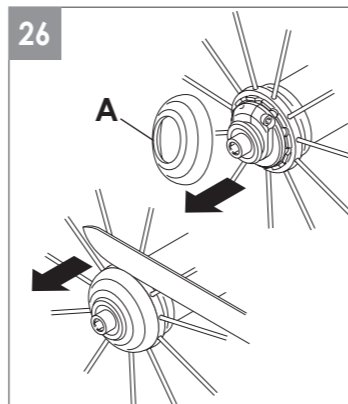
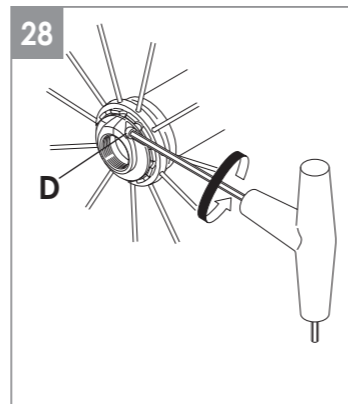
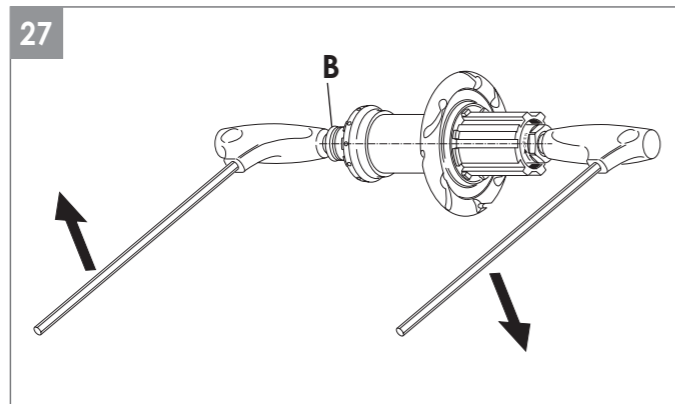

- Unscrew and remove the lock ring (**C** - Fig. 29), press the axle (**G** - Fig. 29) towards the hub body, making sure that the freehub body comes out of its seat; slide out the axle axle-freehub body unit, remove the ring (**F** - Fig. 29), the cone (**H** - Fig. 29), the cone (**I** - Fig. 29), the gaskets (**J** - Fig. 29) taking care not to damage it and the ball bearings (**K** - Fig. 29).
- If it is necessary to replace the cups, contact a Campagnolo Service Center®.
- Carefully clean the components, grease the ball bearings and proceed to refit the system performing disassembly operations in reverse order.

Attention

When inserting the axle, be careful not to move the ball bearings out of their seats.

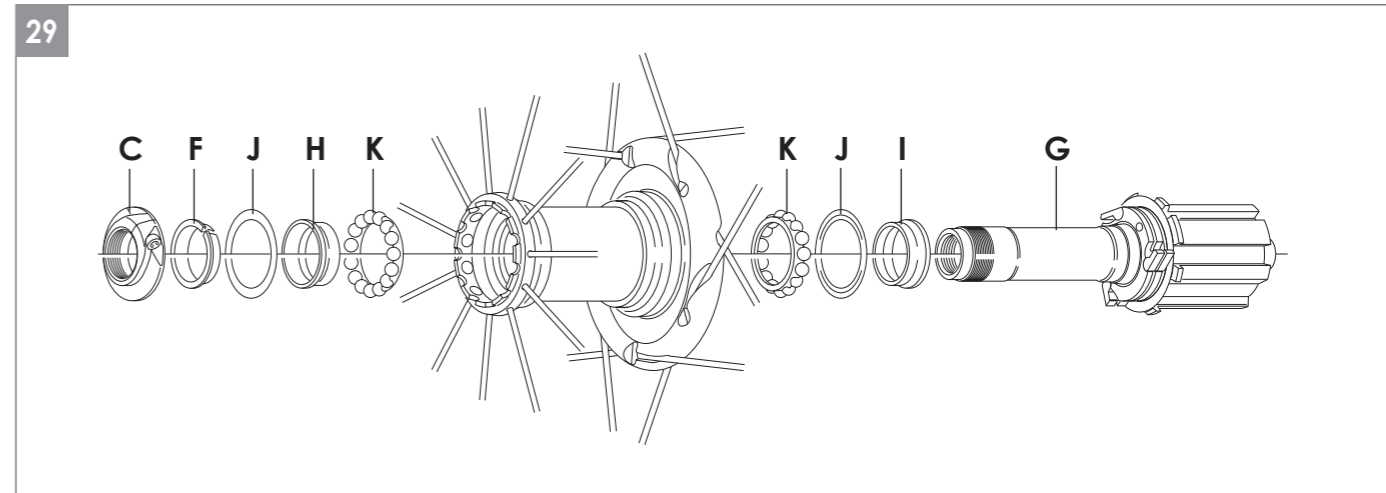

- Position the freehub close to the hub and hold it pressed against the latter; lower one by one the three pawls with an Allen wrench or a screwdriver and insert freehub fully into its seat (Fig. 30).
- Tighten the locking nut (E - Fig. 31) with a 17 mm wrench, holding the axle steady from the freehub side with a snugly fitted 5 mm Allen wrench (approximate torque setting: 15 N.m - 11 lb.ft).
- Adjust the hub as illustrated in section 7.

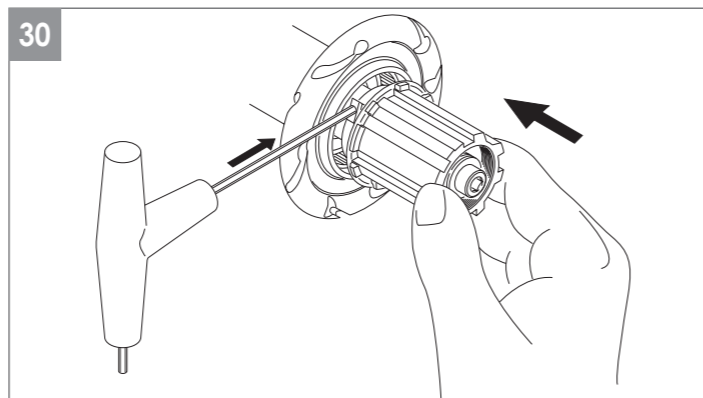

6.3 - REMOVING THE FREEWHEEL BODY

Hold the axle steady by fully inserting a 5 mm Allen wrench on the freewheel side (Fig. 32) and completely unscrew the nut by turning it clockwise as shown by the arrow marked on it; then remove the small axle body.

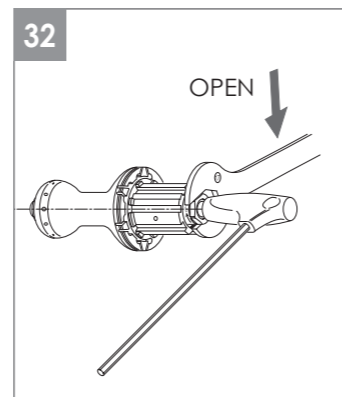
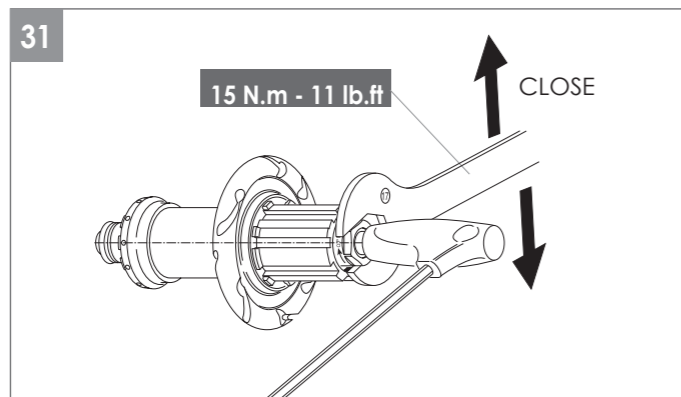

6.4 - REMOVAL AND INSTALLATION OF PAWLS

Remove the spring by slightly raising the pawl (A - Fig. 33), being careful not to distort it. Pull out the pawls and replace them if necessary. Insert the bent part of the spring into the hole of the pawl carrier. Fit the spring between the openings in each pawl, simultaneously setting the pawls into their final position (Fig. 34A). When the operation is complete make sure that all three pawls rotate freely and remain in the open position (Fig. 34B).

6.5 - FITTING THE FREEWHEEL BODY ON THE HUB

Place the freewheel on the hub and hold it in position, lower the three pawls one by one with the Allen wrench or with a screwdriver and fully insert the freewheel in its seat (Fig. 35). Tighten the locking screw with the 17 mm wrench (Fig. 36), holding the axle steady on the freewheel side with a fully inserted 5 mm Allen wrench (tightening torque: 15 N.m - 11 lb.ft).

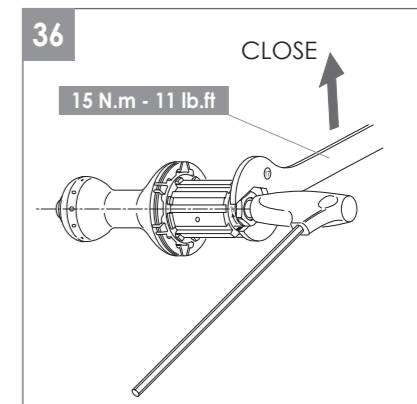
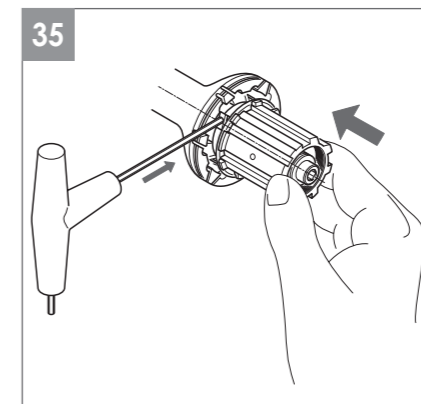
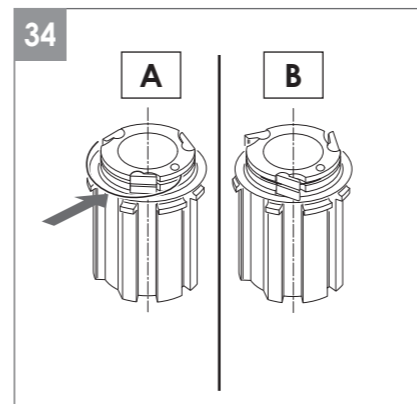
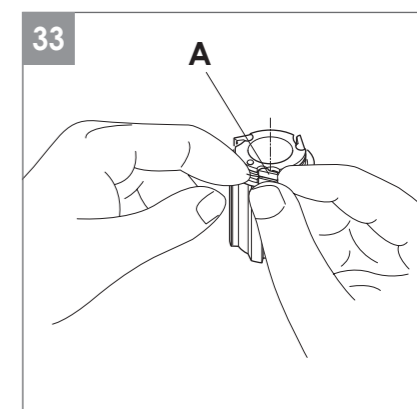

7. HUBS ADJUSTMENT

- Using a stiff blade (such as small knife) positioned as indicated in Fig. 21 (page 14) and taking care not to damage the hub or the spokes, remove the side covers from the hub.
- Fully insert the 2.5 mm Allen wrench into screw **(A - Fig. 37)** and tighten it by about three (3) turns.
- To reduce axle clearance, tighten locking **(B - Fig. 37)** by turning it clockwise by hand or with a 21 mm wrench.
- To increase axle clearance, loosen locking **(B - Fig. 37)** by turning it counter-clockwise by hand or with a 21 mm wrench.
Strike screw **(E - Fig. 38)** lightly with the plastic handle of the Allen wrench.
- Tighten the Allen screw **(A - Fig. 37)** with the wrench properly seated on it until the gap **(X - Fig. 37)** on the locking **(B - Fig. 37)** is completely closed.
- Make sure that the adjustment is correct (the axle slides easily and without play), otherwise repeat the adjustment procedure.

