



TECHNICAL MANUAL
FRAME SPECIFICATIONS AND INTERFACE

Campagnolo®

CAUTION!

ALWAYS wear protective gloves and glasses while working on the bicycle.

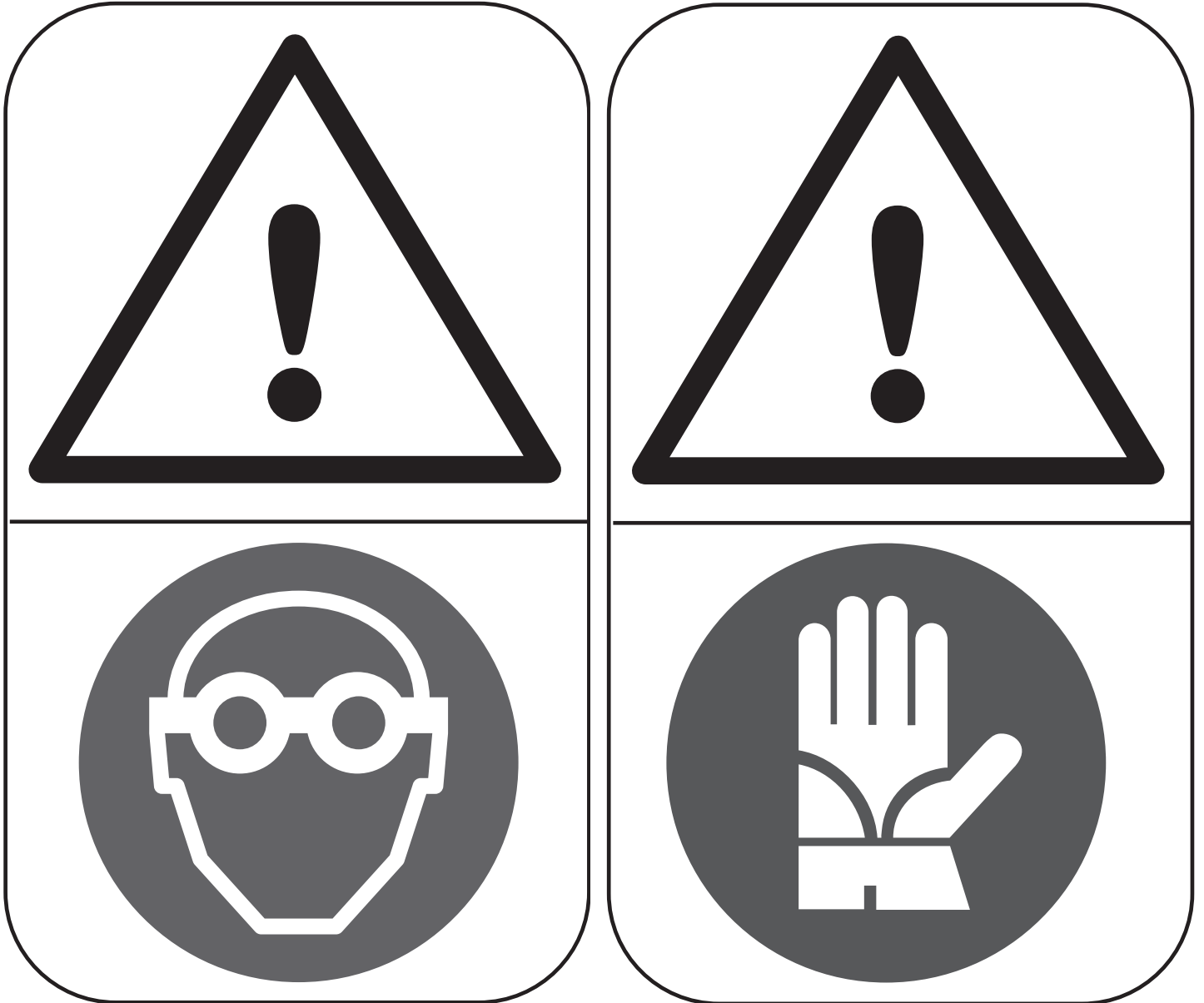

THIS TECHNICAL MANUAL IS INTENDED FOR USE BY PROFESSIONAL MECHANICS.

Anyone who is not professionally qualified to assemble bicycles should not attempt to install and operate on the components because of the risk of carrying out incorrect operations that could cause the components to malfunction with the consequent risk of accidents, physical injury or even death.

The actual product may differ from what is illustrated, as the specific purpose of these instructions is to explain the procedures for using the component.



FRAME SPECIFICATIONS AND INTERFACE

1 - PREPARING THE FRAME / FORK SPECIFICATIONS

1.1 - FORK SPECIFICATIONS FOR THE FRONT CALLIPER

- Remove all traces of paint from the areas where the callipers are to be installed on the fork and the left-hand chain stay. Also remove all traces of paint from the bottom part of the holes on the chain stay, where the rear calliper screw heads rest (Fig. 1 / Fig. 1.1).

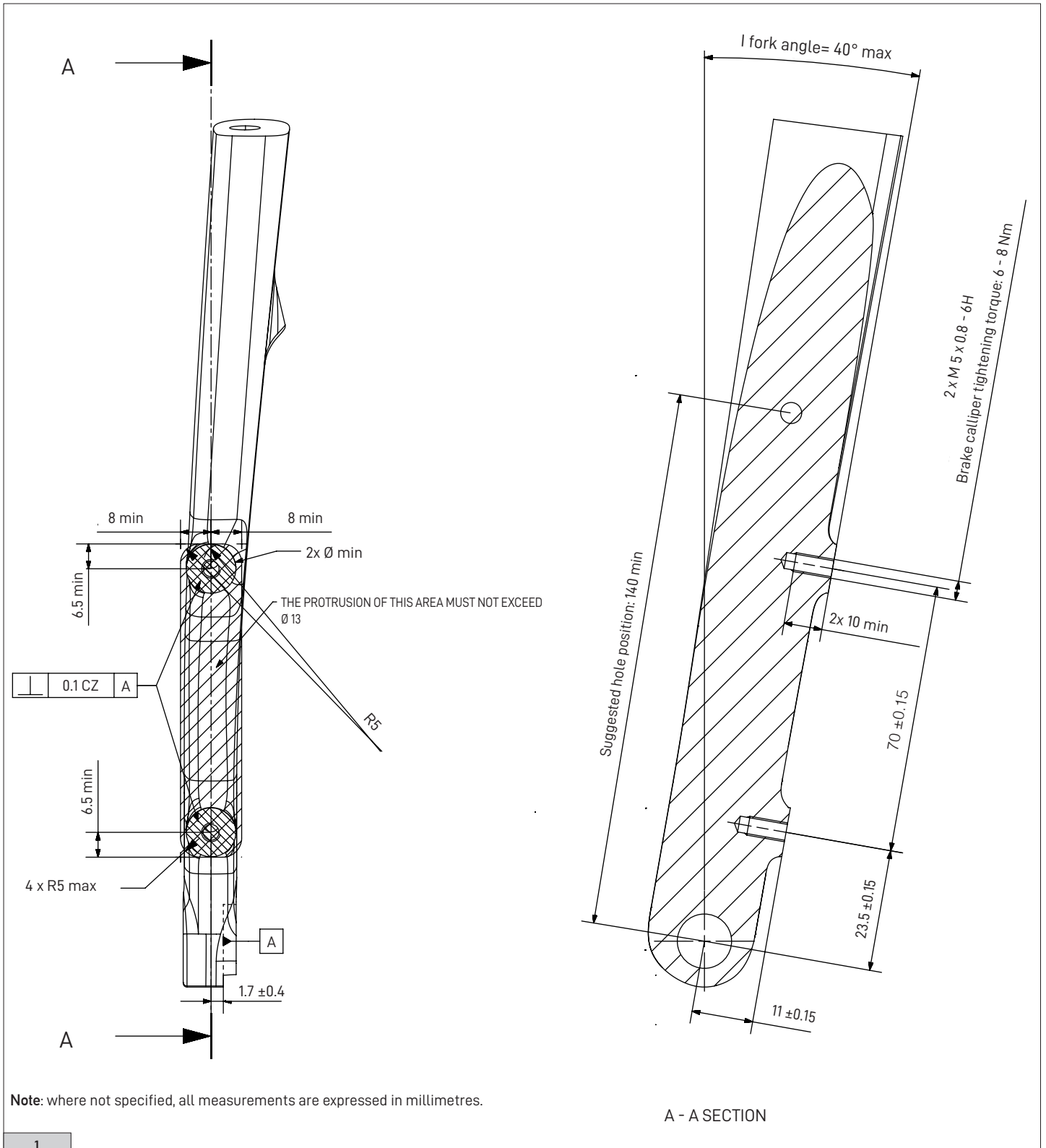

1.2 - LEFT-HAND CHAIN STAY FOR REAR CALLIPER

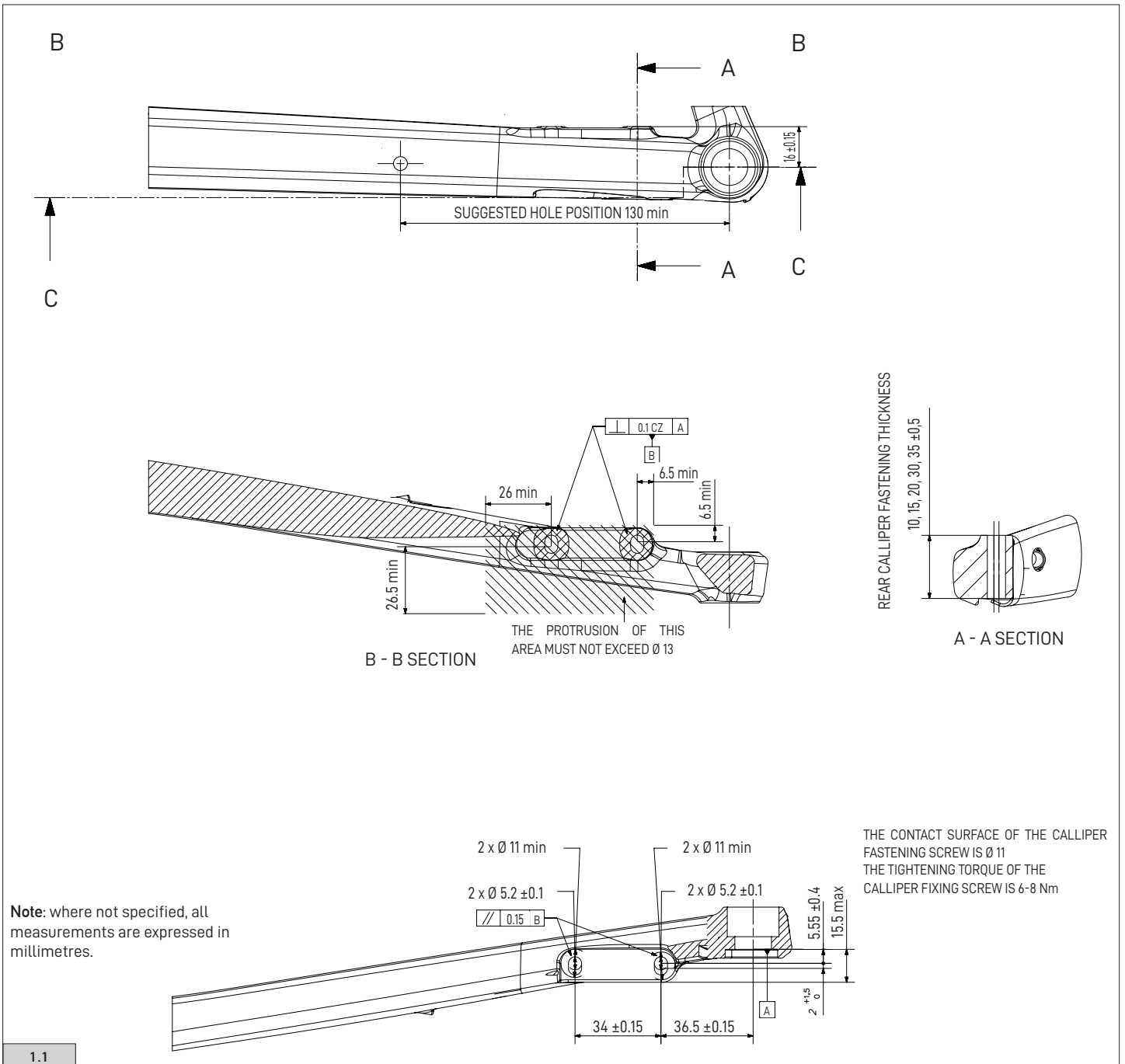

- Using the frame cutter tool make sure the calliper contact surface on the fork and the left-hand chain stay are perpendicular to the discs, grinding the frame if necessary in order to achieve this (Fig. 2).

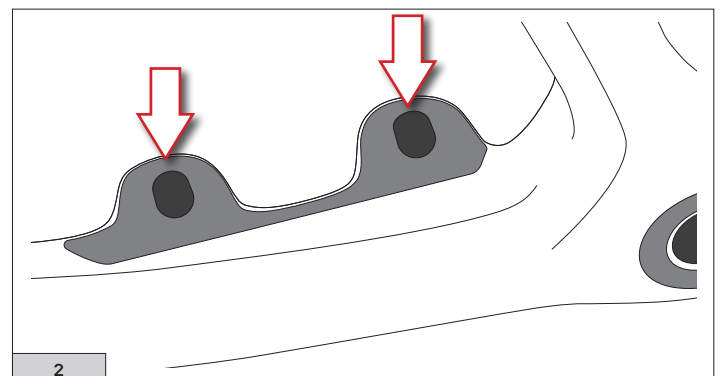

2 - ERGOPOWER CONTROL LEVERS

2.1 - INTERFACE WITH HANDLEBAR FOR ERGOPOWER CONTROL LEVERS



CAUTION!

Control levers incorrectly attached to the handlebar could cause accidents or physical injury or death.

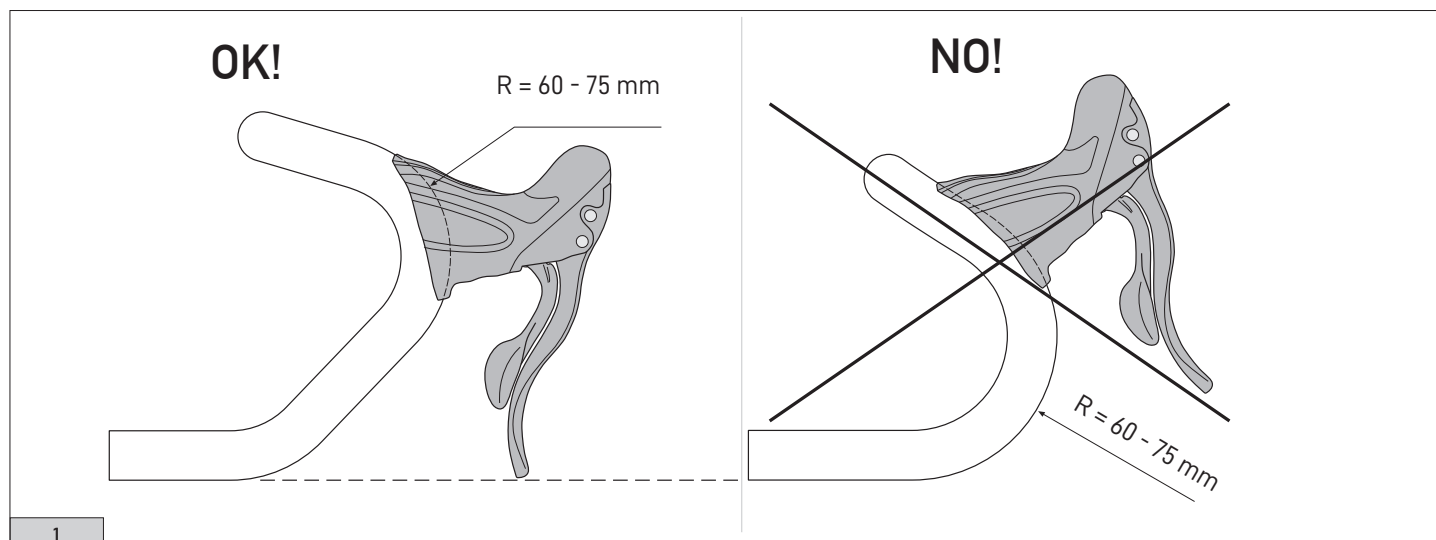

- Do not lodge the upper part of the command in the rectilinear section of the handlebar (Fig. 1).
- Lodge the command in the curved section measuring $R = 60 - 75$ mm with a diameter = 23.8 - 24.2 mm (including any ovalization) to guarantee more effective fastening (Fig. 1).

WARNING: Make sure that the curved section of the handlebar where the command is to be fixed, has a sufficiently rough surface to ensure a better grip.

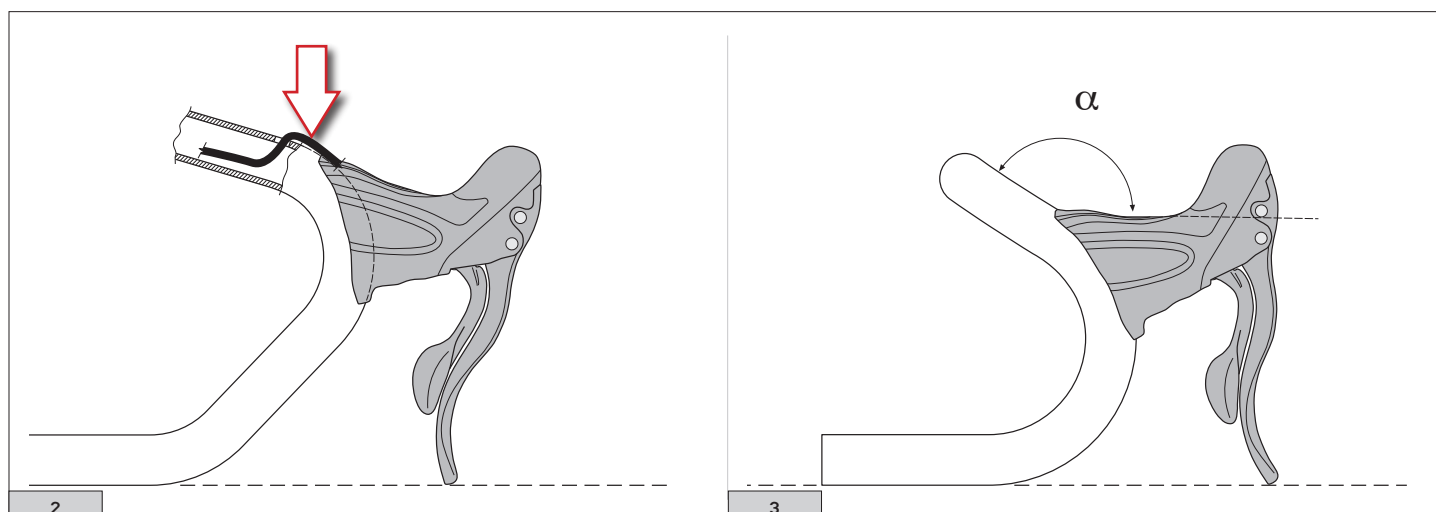

WARNING: The cable routing illustrated in Figure 2 seriously compromises the drivetrain's gear shift and derailing performance. **DO NOT USE HANDLEBAR BENDS WITH THIS KIND OF ROUTING.**

- Make sure that angle α is sufficiently wide to ensure that the housing is mounted correctly and the cable runs through it easily (Fig. 3).

3 – REAR DERAILLEUR

3.1 – STANDARD DROP-OUTS SPECIFICATIONS

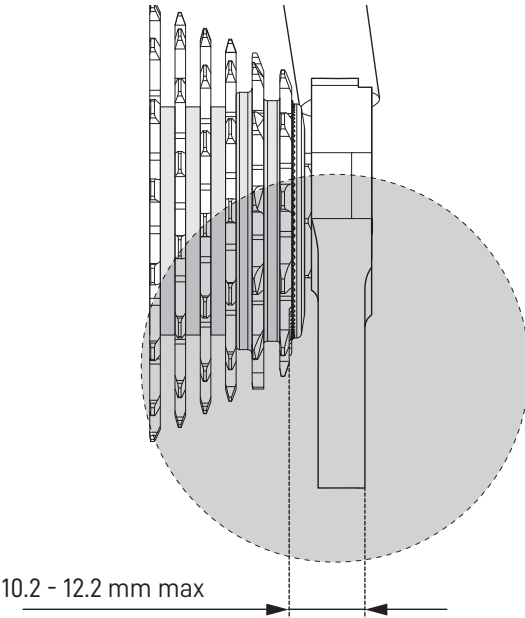

10.2 - 12.2 mm max

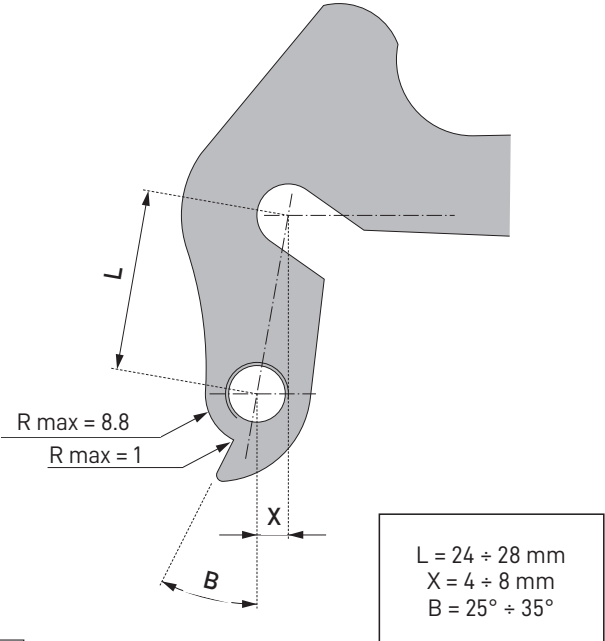

$L = 24 \div 28 \text{ mm}$
 $X = 4 \div 8 \text{ mm}$
 $B = 25^\circ \div 35^\circ$

1

The travel of the jockey cage in function of the cable pull is checked by Campagnolo Quality for each piece produced. The distance of the rear derailleur hanger from the first sprocket influences this travel, therefore it is necessary to remain within the tolerance limit specified on the drawing (Fig. 1).

2

CAUTION!

Campagnolo® rear derailleurs are designed to function with drop-outs produced according to the specifications in Figure 2. For your safety and the functionality of the drivetrain, make sure that the drop-out on your bicycle complies with these specifications. If you are not sure, have your bicycle inspected by a specialised mechanic before using it. Drop-outs outside of these specifications cause a loss, also significant, of functionality.

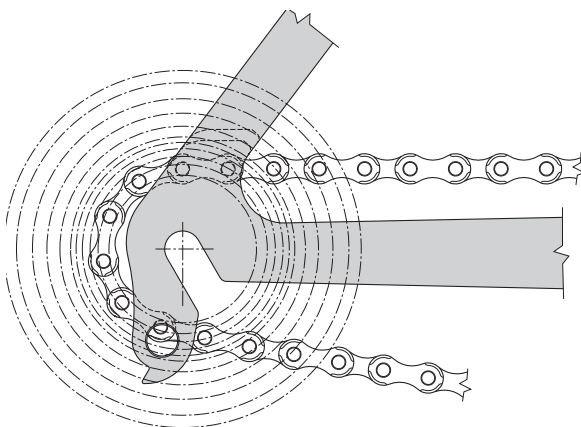

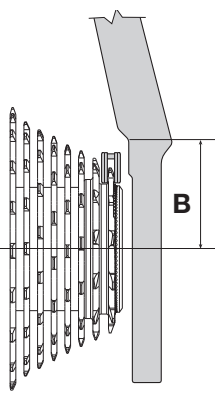

TEETH NO.	B (Fig. 3)
Z 10	30 mm
Z 11	30 mm
Z 12	30 mm
Z 13	32 mm

3

3.2 - DIRECT MOUNT DROP-OUTS SPECIFICATIONS

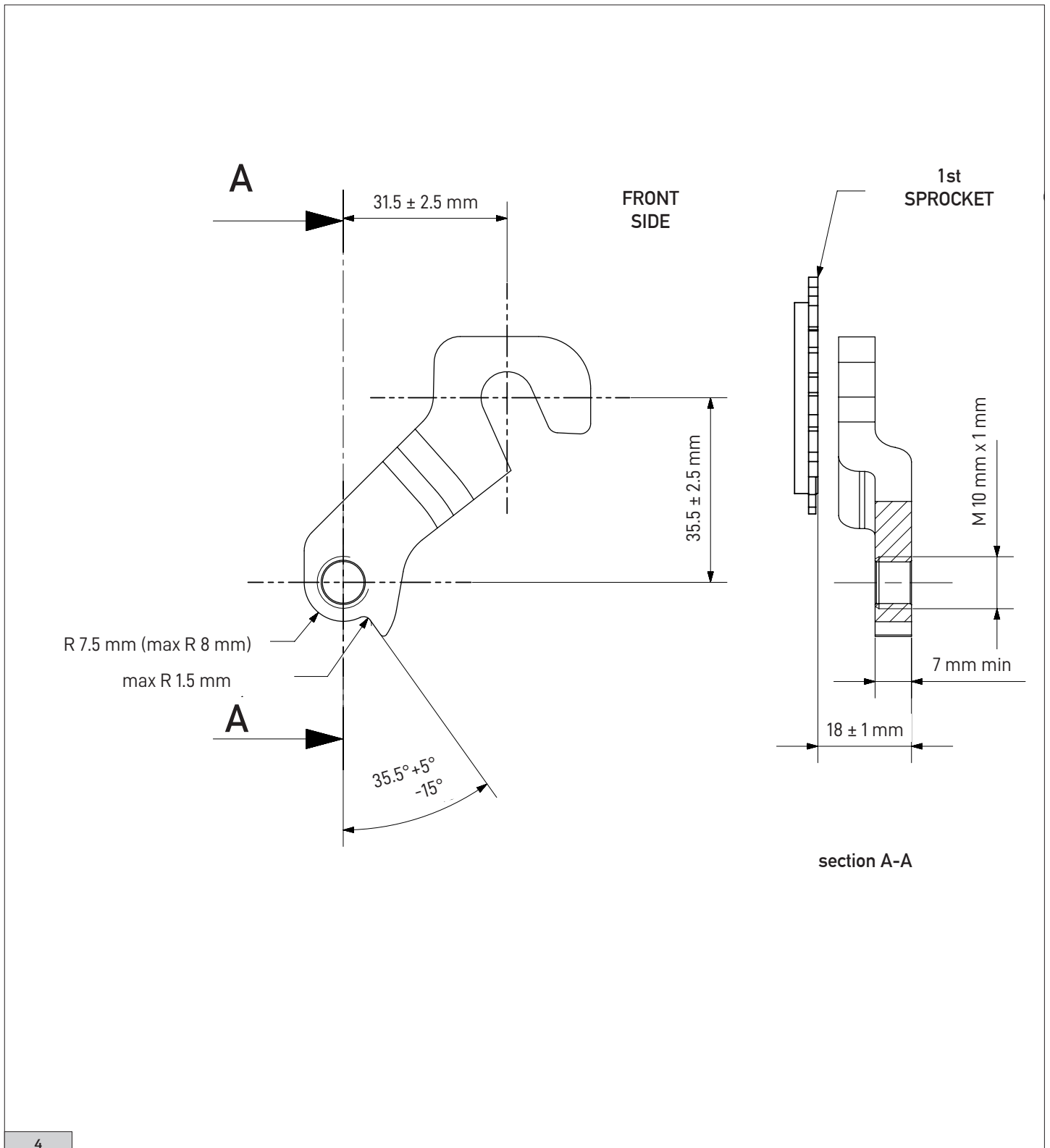

3.3 - FRAME SPECIFICATIONS

Height of the chain stay near the sprocket cassette: $B < 7 \text{ mm}$

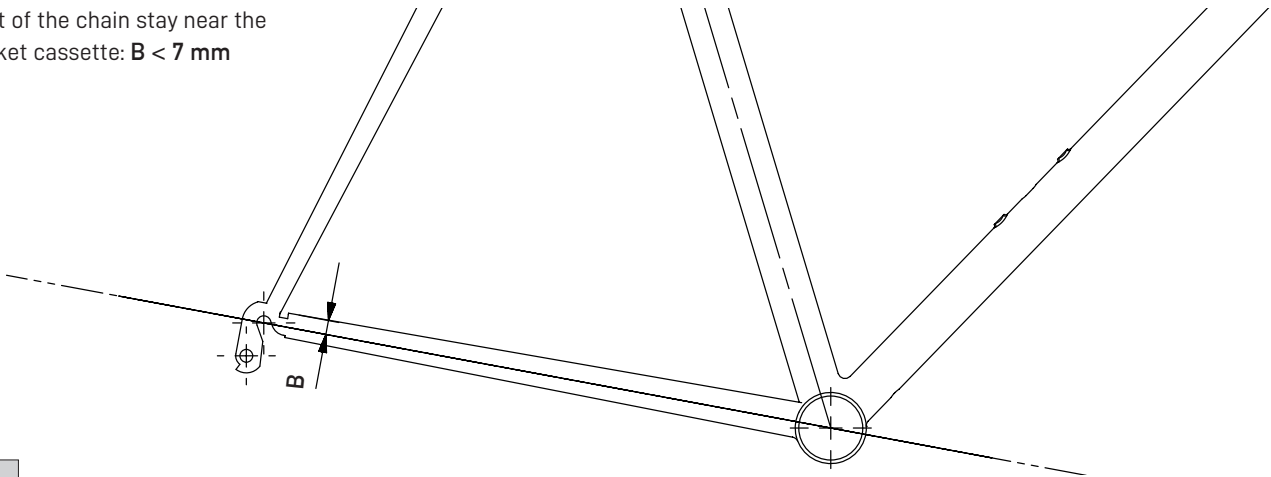

5

3.4 - MINIMUM CHAINSTAY LENGTH

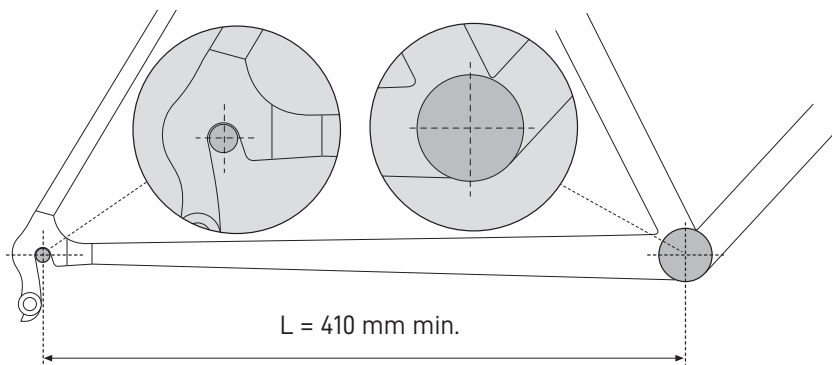

6

3.5 - PREPARING THE FRAME

Check and if necessary adjust the alignment of the rear derailleur hanger, using only the Campagnolo® tool UT-VS030 (Fig. 5). Never straighten the drop-out with the rear derailleur installed because you could damage the drop-out itself and cause irreversible damage or loss of functionality to your rear derailleur.

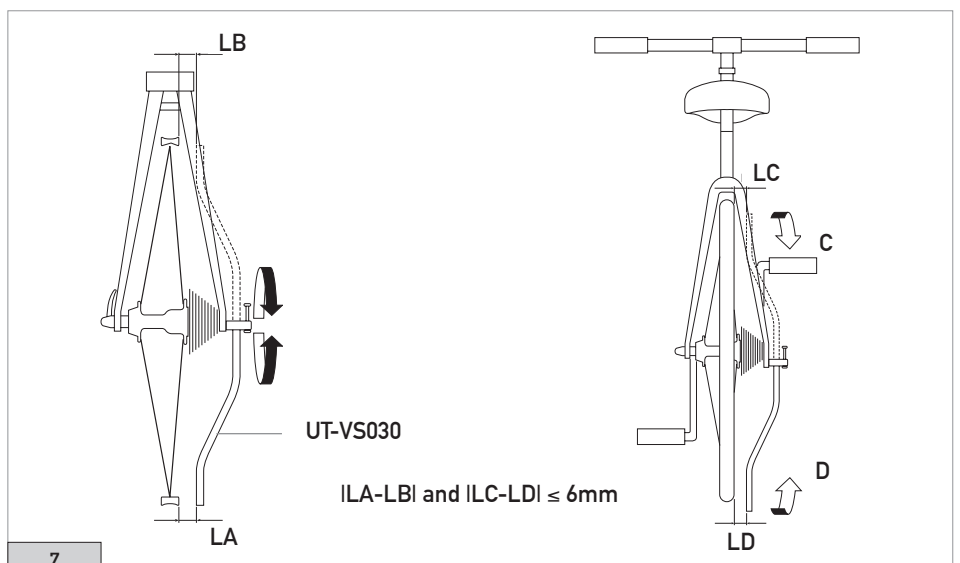

7

4 – FRONT DERAILLEUR

4.1 – BRAZED ON VERSION

External chainring teeth	L mm
45	139
48	145
50	149

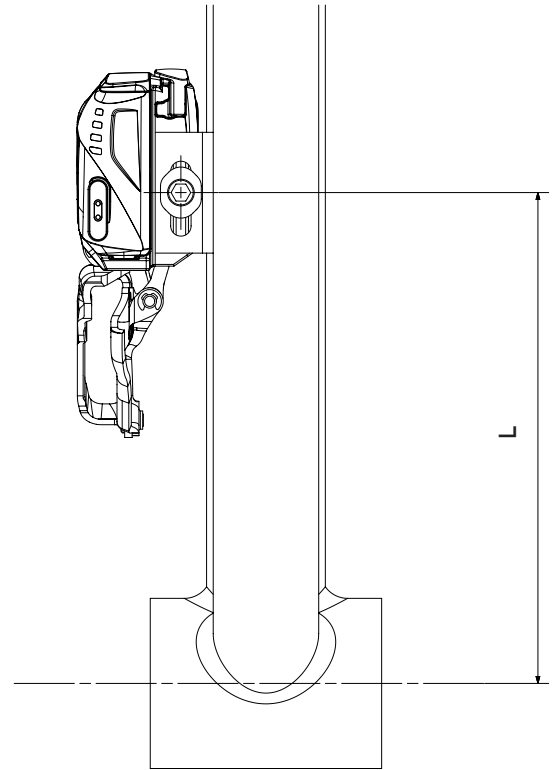

1

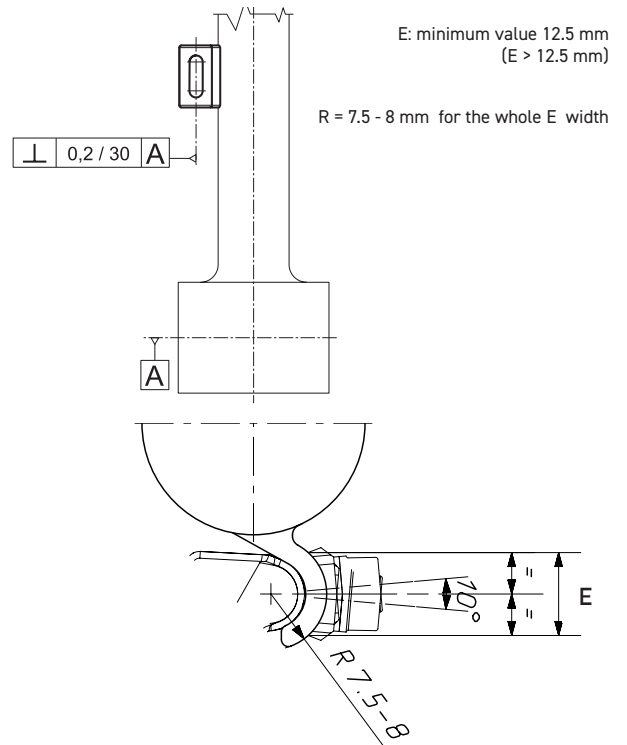
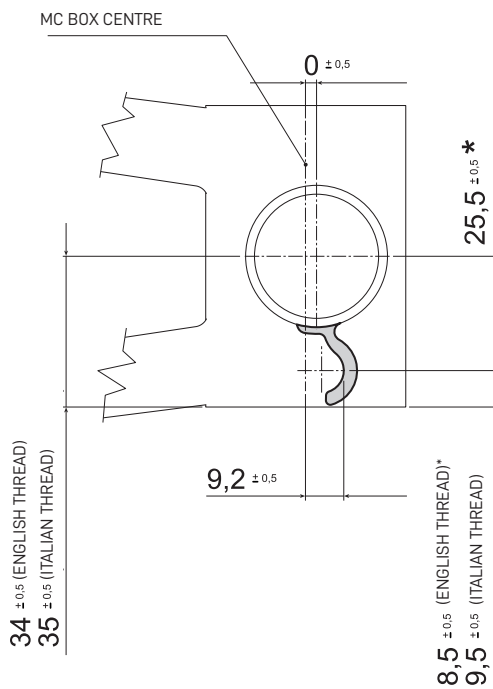

2

(*) ONE OF THE TWO VALUES MUST BE SATISFIED

Note: where not specified, all measurements are expressed in millimetres.

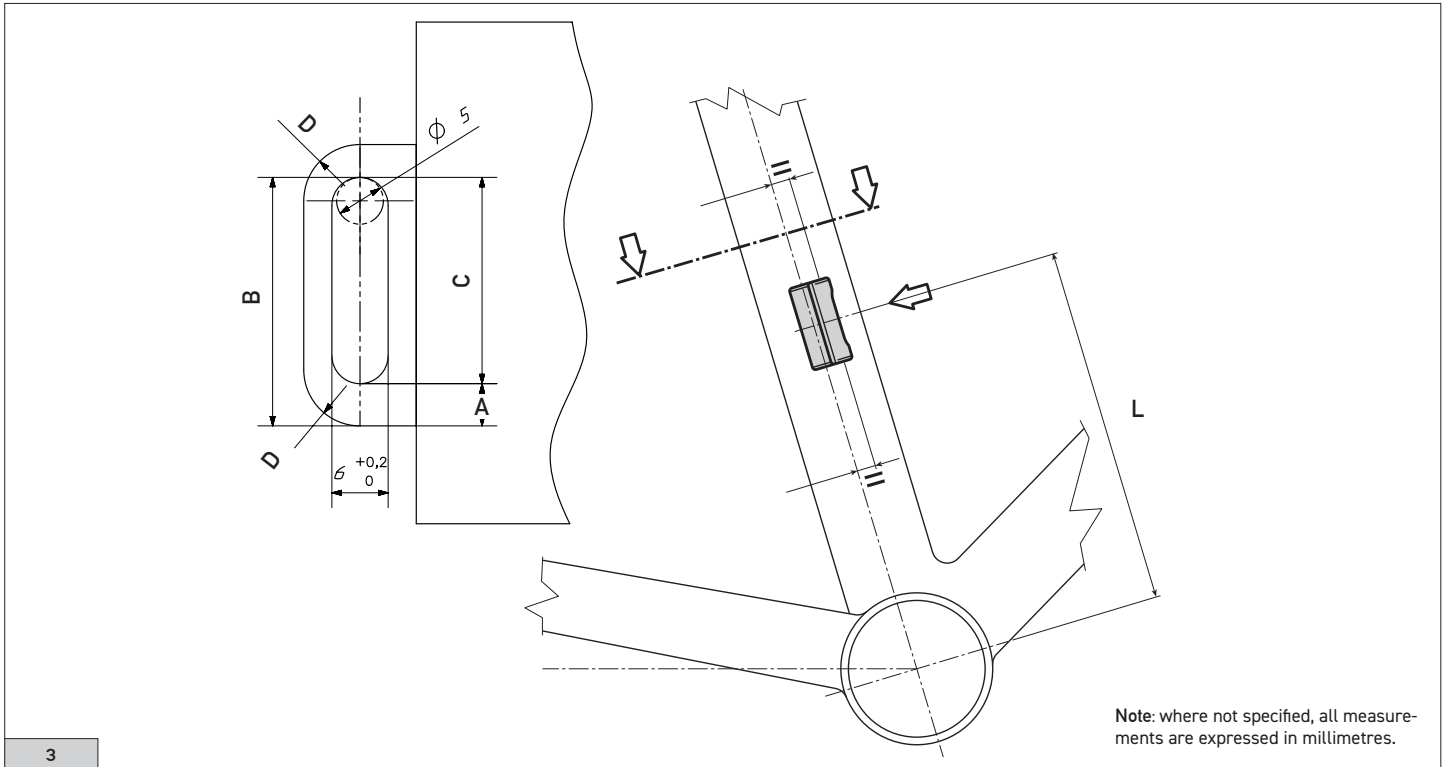

3

In order to have compatibility with all the chainrings indicated in table 1, the following measurements must be observed:
 C: minimum value 22 mm ($C > 22$ mm) - B: maximum value 27 mm ($B < 27$ mm) - A: maximum value 5 mm.
 Increasing the dimensions of the slot, in other words, the C value, and therefore decreasing A, the compatibility of the chainrings can be increased beyond the indications in figure 1.

4.2 - CLAMP-ON VERSION

WARNING

For frames with a 35 mm hose diameter, use only Campagnolo clamp-ons, code DC12-SR5B.

WARNING
Leave the frame in the area corresponding to L free.

External chainring teeth	L mm
45	153
48	159
50	163

$\varnothing 32 \pm 0.2$	$\varnothing 35 + 0.8 / - 0.2$
--------------------------	--------------------------------

4

4.3 - SHEATHS SIZING

α = virtual angle between seat tube passing through front derailleur mount and lower drop-outs

L = lower drop-outs length

The graph assumes that the front derailleur fixing screw axis is perpendicular to the axis of the seat tube.

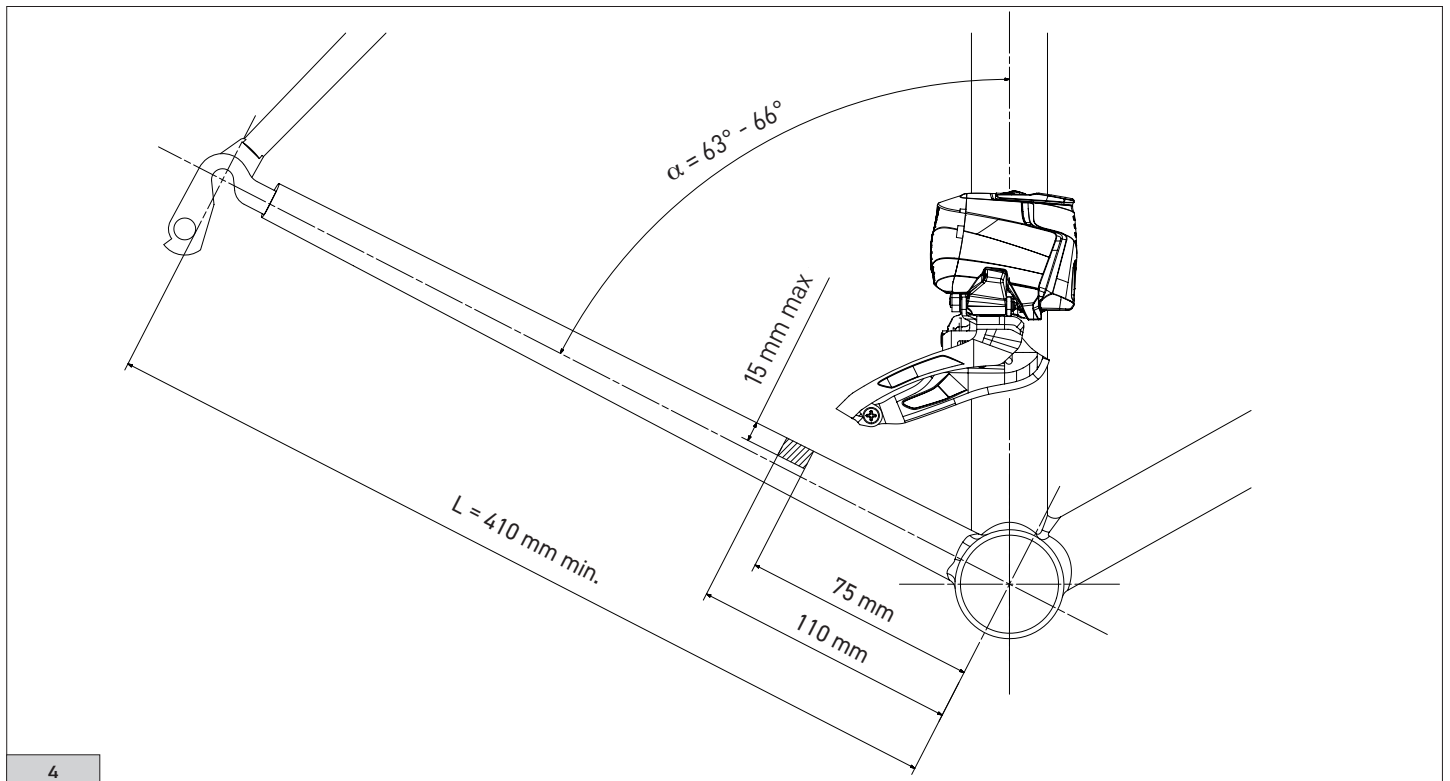

4

4.4 - FRONT DERAILLEUR DIMENSIONS

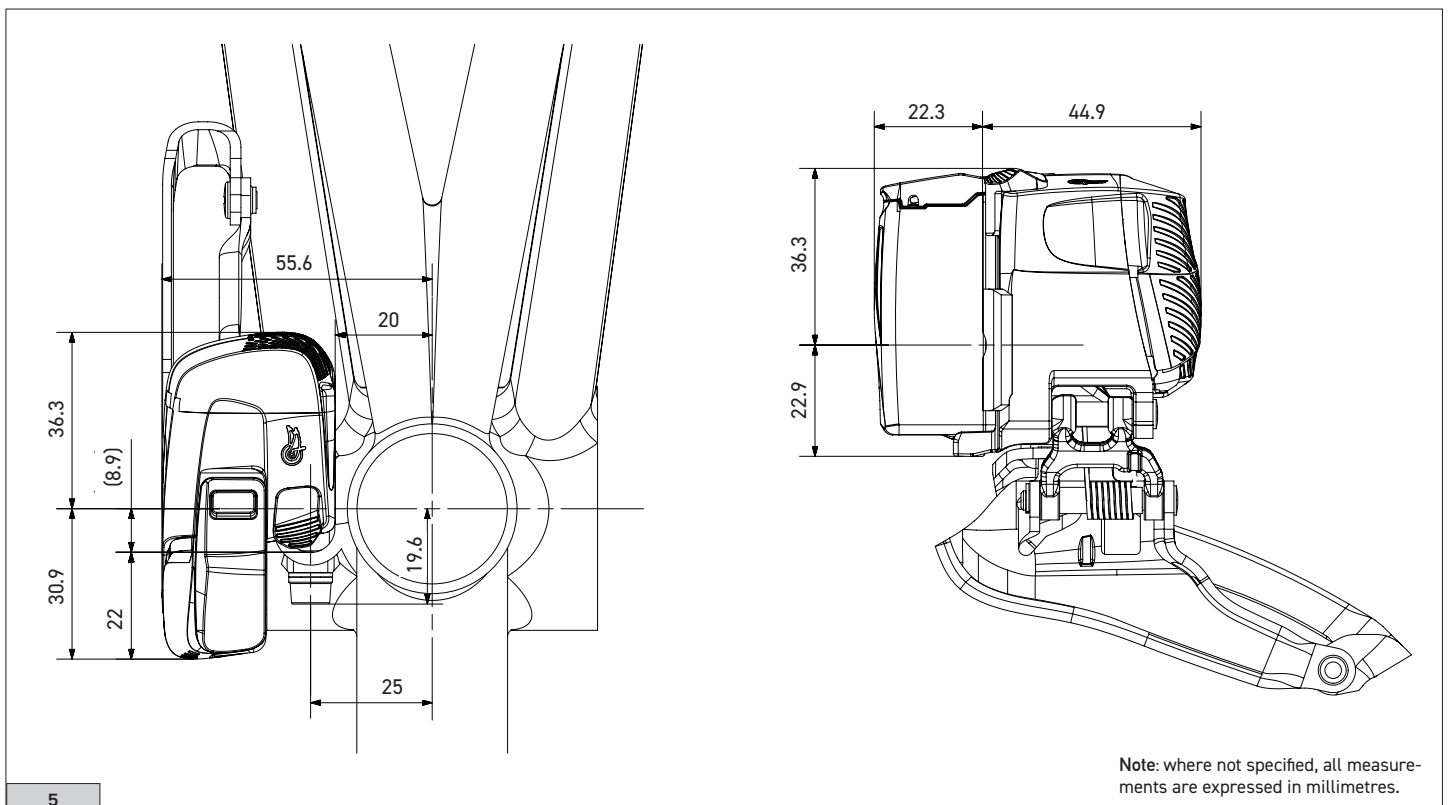

Note: where not specified, all measurements are expressed in millimetres.

5

5 - CRANKSET

5.1 - OVERALL DIMENSIONS FOR THE PRO-TECH 12s CRANKSETS

! CAUTION!

The 12s cranksets are compatible SOLELY AND EXCLUSIVELY with 12s wireless groupsets.

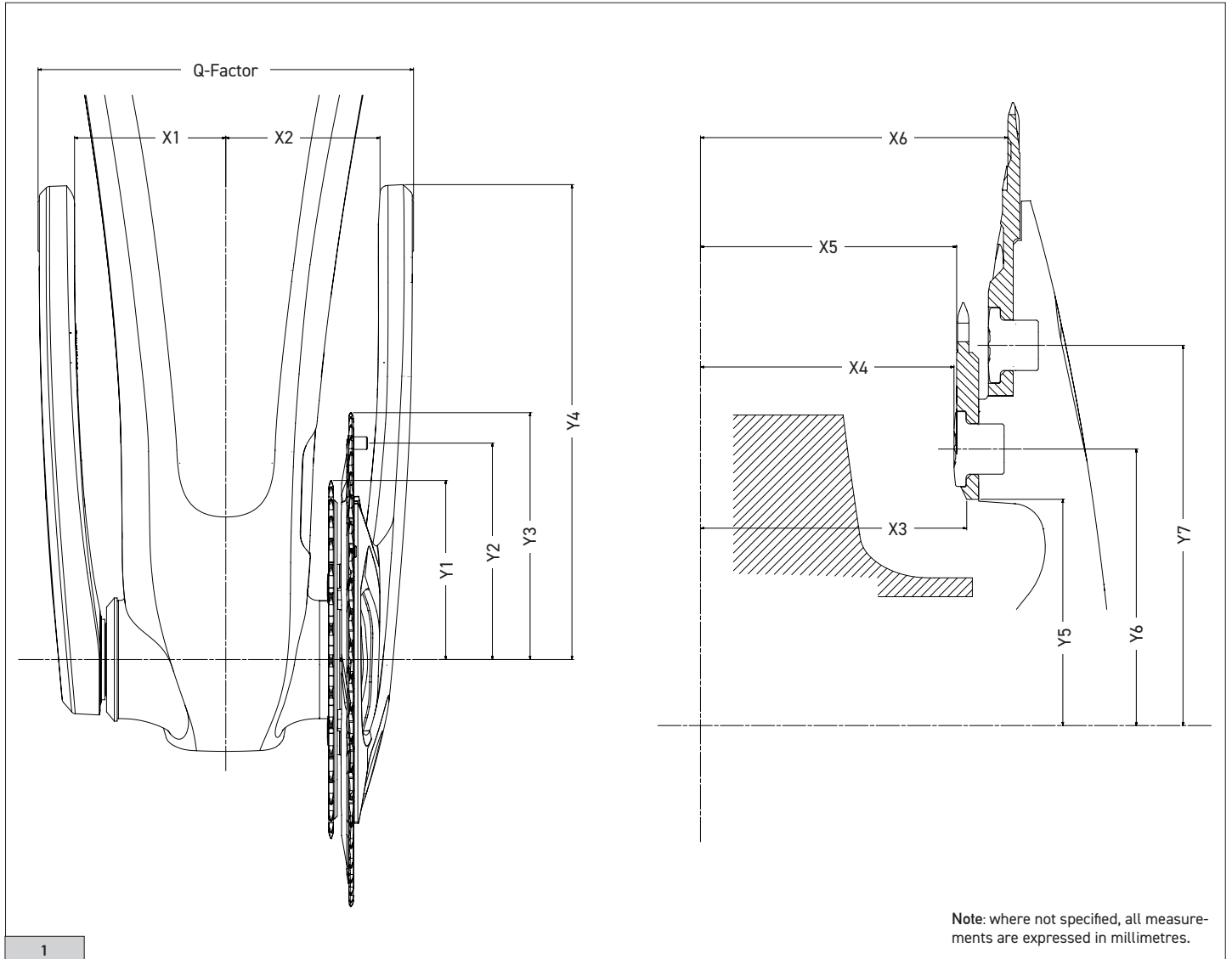

Crankset	X1	X2	X3	X4	X5	X6	Y1	Y2	Y3	Y4	Y5	Y6	Y7	Q-Factor
50 - 34							71.5	91.5	103.5					
48 - 32	58.0	59.5	42	40	+0.8	48.8	67.5	86	99.5	191	36	44	60.5	148
45 - 29							61.5	81	93.5					

5.2 - MEASUREMENT OF THE CHAIN LINE

Chain line for double crankset: 45.8 mm (Fig.2)

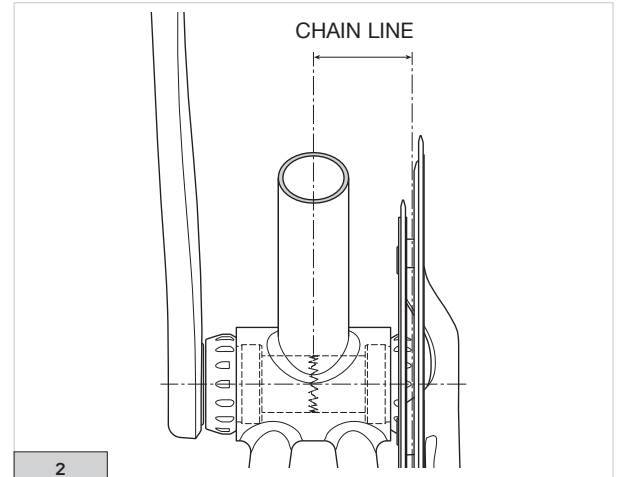

5.3 - OVERALL DIMENSIONS FOR THE PRO-TECH 12s CRANKSETS

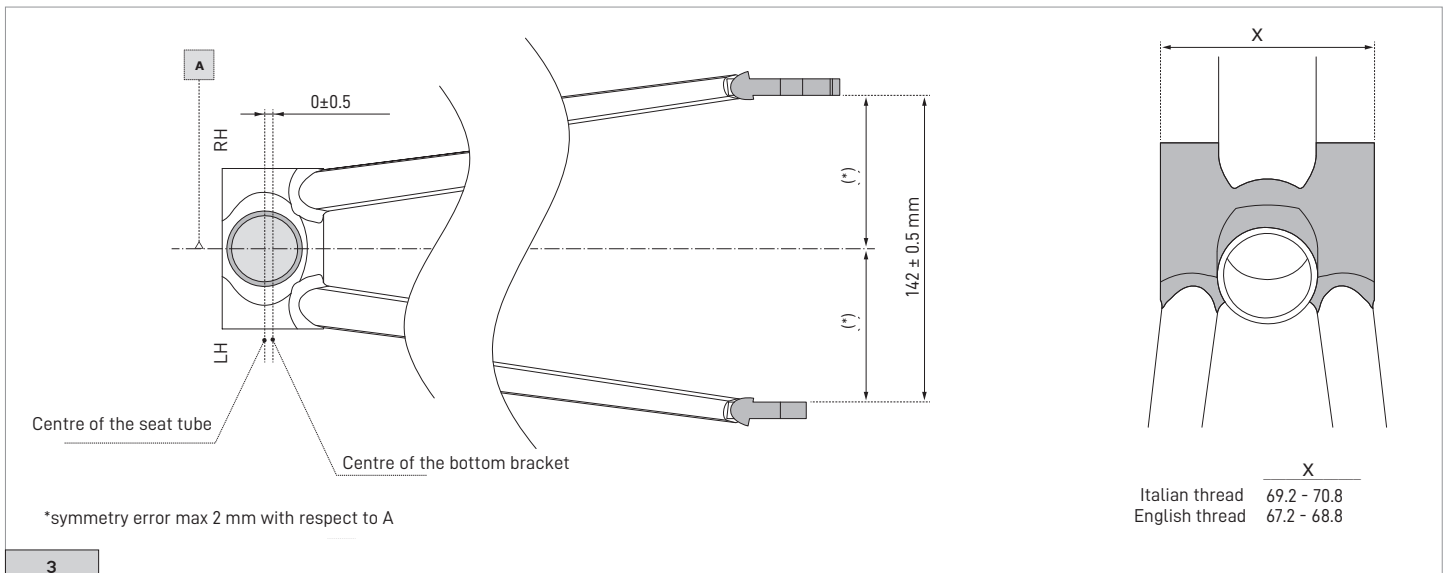

5.4 - PIVOT PEDAL COMPATIBILITY

CAUTION!

Do not put washers between the pedal axle and hand crank as they would give rise to abnormal tensions in the interface area. Such tensions could lead to premature breaks and be the cause of accidents, physical injuries or even death.

The stop chain ring of the pedal pivot must respect the dimensions indicated in Fig.4.

These conditions are necessary to minimise the possibility of abnormal tensions in the hand cranks. Such tensions could lead to premature breaks and be the cause of accidents, physical injuries or even death.

NOTE

Q-factor: 145.5 mm (nominal value).

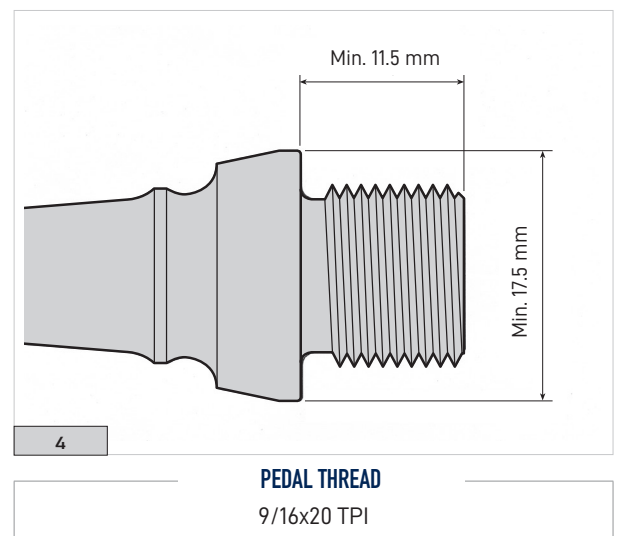

6 - 12s SPROCKETS

6.1 - TECHNICAL SPECIFICATIONS AND COMPATIBILITIES

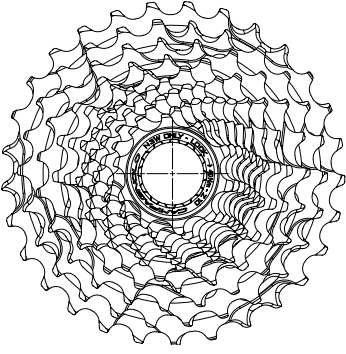
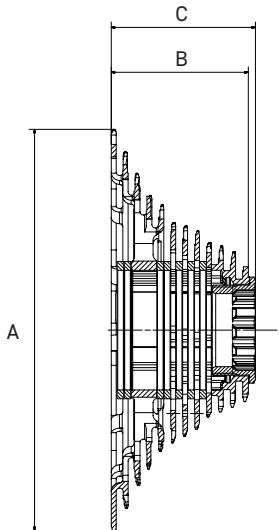
MIN. SPROCKET	10	
MAX. SPROCKET	29	
BODY	N3W	
CHAIN	12s C-LINK	
	12s ULTRA-LINK	
FASTENING RING NUT	Z10 for N3W	

SPROCKET CASSETTE	A (mm)	B (mm)	C (mm)
10 - 25	102.5	40.35	42.4
10 - 27	110.5	40.35	42.4
10 - 29	118.5	40.35	42.4

7 - PRO-TECH CUPS

7.1 - BOTTOM BRACKET FOR THREADED CUPS

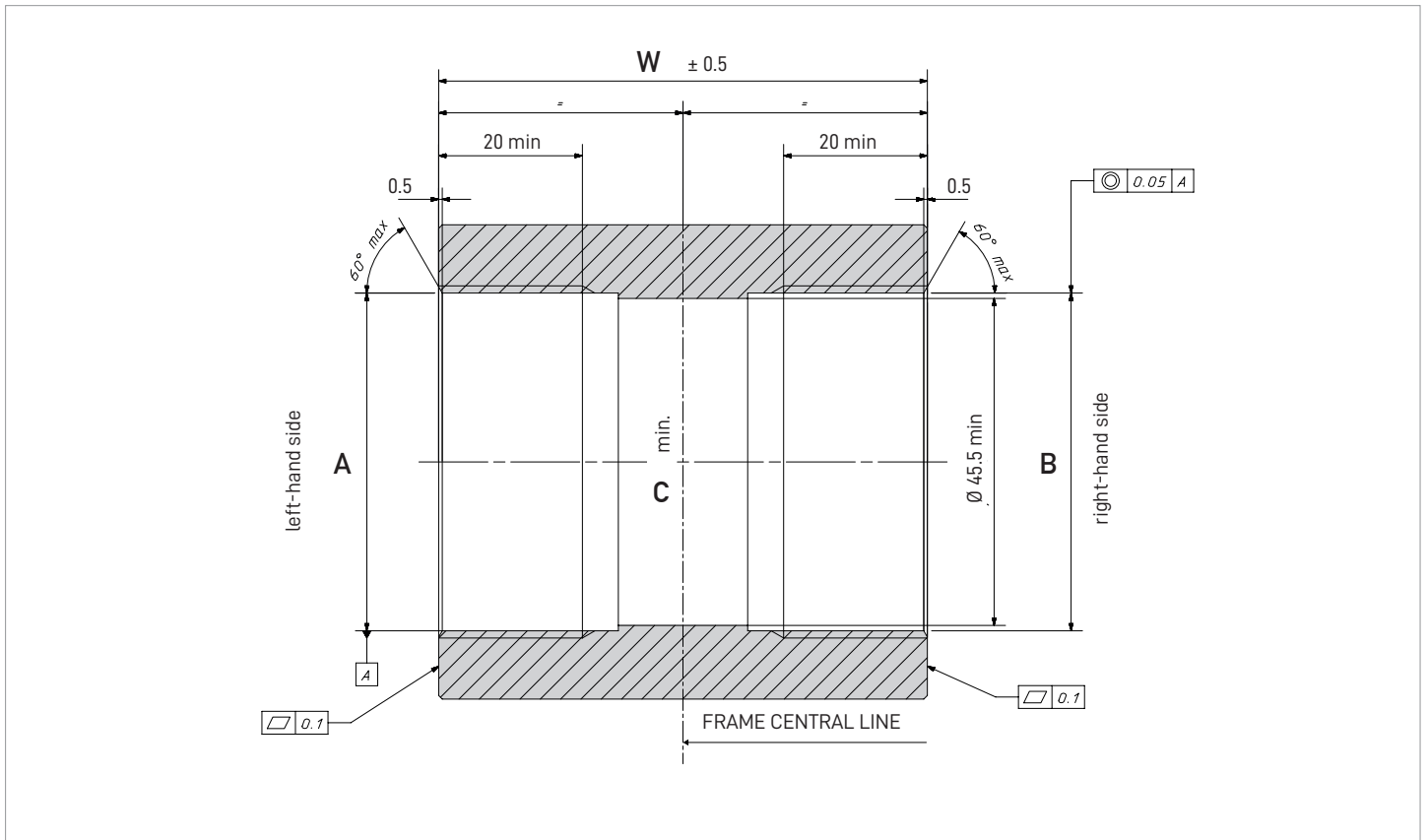

MODEL	W	A	B	C
ENG	70	36 mm x 24 TPI R.H.		33
BSA	68	1.37"x24 TPI R.H.*	1.37"x24 TPI L.H.*	33
T47 x 86	85.5	47 x 1M - RH	47 x 1M - LH	45.5
T47 x 68	68	47 x 1M - RH	47 x 1M - LH	45.5

*Ref. JIS B 0225

Note: where not specified, all measurements are expressed in millimetres.

7.2 – BOTTOM BRACKET FOR PRESS-FIT CUPS

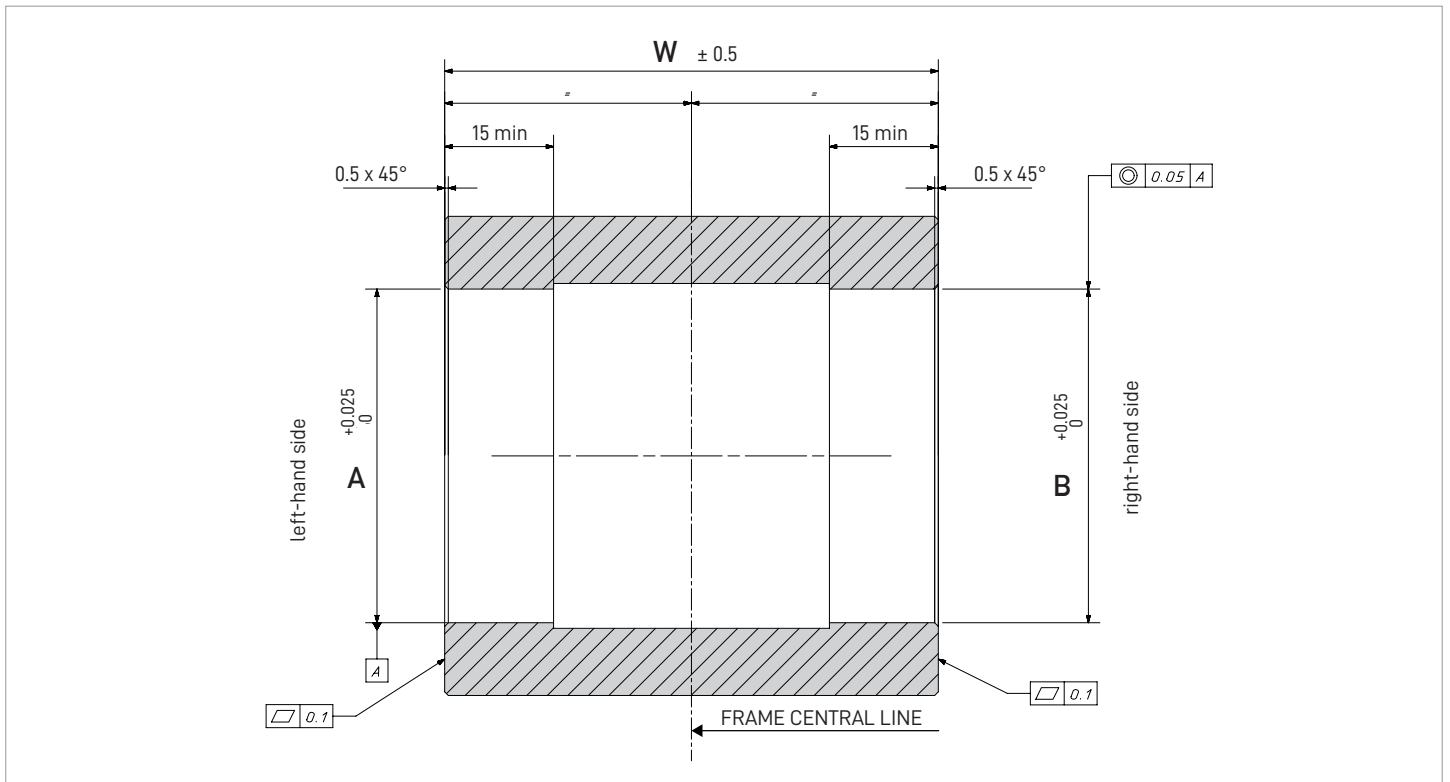

MODEL	W	A	B
BB86	86.5	41	41
PF30	68	46	46
BB386	86.5	46	46
BB Right	79	46	46
BB30	68	42	42

Note: where not specified, all measurements are expressed in millimetres.